

WIRING DIAGRAMS

Models PDP/BDP gas-fired unit heaters

Diagram Selection

Diagrams are provided for both single and three-phase circuits, and are readily identified in the Selection Table on the following page. The Selection Table enables easy selection of the correct wiring diagram after the electrical components of the unit heater have been determined. The control codes are listed to aid in locating the correct diagram.

Diagram Interchangeability

The following gas-fired unit heater wiring diagrams are for either 115-volt, 60-Hertz, single-phase power, or for 230-volt, 60 Hertz, three-phase electrical service.

The 115v/60Hz/1 ϕ diagrams may also be utilized for 230v/60Hz/1 ϕ by substituting 230-volt components for the 115-volt shown.

The 230v/60 Hz/3 ϕ diagrams may be modified to 460v/60 Hz/3 ϕ by adding a 460v to 230v step down transformer and wiring the unit as shown in the wiring "inset" on all 3-phase wiring diagrams.

The 460v/60Hz/3 ϕ diagrams may also be utilized for 575v/60Hz/3 ϕ by substituting 575-volt components for the 460-volt shown.

NOTE: As indicated in every diagram, all wiring must comply with the National Electrical Code and all local codes. All components must agree with their respective power source.

CAUTION

Turn off all power and gas to unit before wiring. Failure to wire this unit according to this wiring diagram may result in injury to the installer or user. For deviations, contact factory.

Abbreviations and Symbols

To facilitate interpretation and enable simplification the abbreviations and symbols have been selected as recommended by ANSI (American National Standards Institute) and NEMA (National Electrical Manufacturers Association) standards.

XFMR or TR	Transformer
V	Volts
Hz	Cycle or Hertz
ϕ	Phase
LC	Limit Control
THERM or TH	Thermostat
MV	Main Valve
PV	Pilot Valve
SO	Shut Off
RC	Relay Contact or Coil
G	Ground
H	Hot
SW	Switch
EPS	Electric Pilot Switch
HI	High
Lo	Low
C	Common
"J" Box	Junction Box
H1, H2, etc.	Transformer Primary Terminals
SUM	Summer Contact (Summer/Winter Switch)
WIN	Winter Contact (Summer/Winter Switch)
S-W	Summer/Winter Switch
O.L.C.	Overload Contact
C.S.	Power Venter Centrifugal Switch
FTc	Fan Timer Contact
SPDT	Single-Pole Double-Throw Switch
VA	Volt-Ampere
W	Watts

Wire Color Coding

BK	Black
BL	Blue
R	Red
W	White
Y	Yellow
X1,X2, etc.	Transformer Secondary Terminals
L1, L2, etc.	Electric Load Terminals
T1, T2, etc.	Starter or Motor Terminals

6-446 — MODELS PDP/BDP

Unit Power Requirements (AMPS) – PDP Models

Power Supply	PDP 30, 50	PDP 75, 100	PDP 125, 150	PDP 175, 200	PDP 250	PDP 300	PDP 350, 400
115/1	2.7	3.3	4.0	5.1	7.7	9.8	11.1
208/1	1.3	1.9	1.9	2.8	-	-	-
208/1 ①	2.4	2.4	2.4	4.8	4.8	7.2	7.2
230/1	1.3	1.9	1.9	2.8	3.7	4.7	5.5
230/1 ①	2.2	2.2	2.2	3.3	4.4	6.5	6.5
208/3 ①	2.4	2.4	2.4	4.8	4.8	7.2	7.2
230/3 ①	2.2	2.2	2.2	3.3	4.4	6.5	6.5
460/3 ①	1.1	1.1	1.1	1.6	2.2	3.3	3.3
575/3 ①	0.9	0.9	0.9	1.3	1.7	2.6	2.6

① With accessory transformer.

Unit Power Requirements (AMPS) – BDP Models

Power Supply	HP	BDP 50	BDP 75	BDP 100	BDP 125	BDP 150	BDP 175	BDP 200	BDP 250	BDP 300	BDP 350	BDP 400
115/1	1/4	6.0	6.0	6.0	6.0	6.0	-	6.0	-	-	-	-
230/1	1/4	4.0	4.0	4.0	4.0	4.0	-	4.0	-	-	-	-
200/3	1/4	2.6	2.6	2.6	2.6	2.6	-	2.6	-	-	-	-
230/3	1/4	2.5	2.5	2.5	2.5	2.5	-	2.5	-	-	-	-
460/3	1/4	1.9	1.9	1.9	1.9	1.9	-	1.9	-	-	-	-
575/3	1/4	1.8	1.8	1.8	1.8	1.8	-	1.8	-	-	-	-
115/1	1/3	7.3	7.3	7.3	7.3	7.3	7.3	7.3	7.3	-	-	-
230/1	1/3	3.8	3.8	3.8	3.8	3.8	3.8	3.8	3.8	-	-	-
200/3	1/3	2.5	2.5	2.5	2.5	2.5	2.5	2.5	2.5	-	-	-
230/3	1/3	2.5	2.5	2.5	2.5	2.5	2.5	2.5	2.5	-	-	-
460/3	1/3	1.9	1.9	1.9	1.9	1.9	1.9	1.9	1.9	-	-	-
575/3	1/3	2.1	2.1	2.1	2.1	2.1	2.1	2.1	2.1	-	-	-
115/1	1/2	10.3	10.3	10.3	10.3	10.3	10.3	10.3	10.3	-	-	-
230/1	1/2	5.3	5.3	5.3	5.3	5.3	5.3	5.3	5.3	-	-	-
200/3	1/2	3.5	3.5	3.5	3.5	3.5	3.5	3.5	3.5	-	-	-
230/3	1/2	3.4	3.4	3.4	3.4	3.4	3.4	3.4	3.4	-	-	-
460/3	1/2	2.4	2.4	2.4	2.4	2.4	2.4	2.4	2.4	-	-	-
575/3	1/2	2.2	2.2	2.2	2.2	2.2	2.2	2.2	2.2	-	-	-
115/1	3/4	13.3	13.3	13.3	13.3	13.3	13.3	13.3	13.3	-	-	-
230/1	3/4	6.7	6.7	6.7	6.7	6.7	6.7	6.7	6.7	-	-	-
200/3	3/4	4.1	4.1	4.1	4.1	4.1	4.1	4.1	4.1	-	-	-
230/3	3/4	4.0	4.0	4.0	4.0	4.0	4.0	4.0	4.0	-	-	-
460/3	3/4	2.6	2.6	2.6	2.6	2.6	2.6	2.6	2.6	-	-	-
575/3	3/4	2.3	2.3	2.3	2.3	2.3	2.3	2.3	2.3	-	-	-
115/1	1	-	15.7	15.7	15.7	15.7	15.7	15.7	15.7	15.7	15.7	-
230/1	1	-	8.0	8.0	8.0	8.0	8.0	8.0	8.0	8.0	8.0	-
200/3	1	-	4.9	4.9	4.9	4.9	4.9	4.9	4.9	4.9	4.9	-
230/3	1	-	4.8	4.8	4.8	4.8	4.8	4.8	4.8	4.8	4.8	-
460/3	1	-	3.0	3.0	3.0	3.0	3.0	3.0	3.0	3.0	3.0	-
575/3	1	-	2.6	2.6	2.6	2.6	2.6	2.6	2.6	2.6	2.6	-
115/1	1-1/2	-	-	-	17.5	-	17.5	17.5	17.5	17.5	17.5	17.5
230/1	1-1/2	-	-	-	8.9	-	8.9	8.9	8.9	8.9	8.9	8.9
200/3	1-1/2	-	-	-	6.1	-	6.1	6.1	6.1	6.1	6.1	6.1
230/3	1-1/2	-	-	-	6.1	-	6.1	6.1	6.1	6.1	6.1	6.1
460/3	1-1/2	-	-	-	3.6	-	3.6	3.6	3.6	3.6	3.6	3.6
575/3	1-1/2	-	-	-	3.1	-	3.1	3.1	3.1	3.1	3.1	3.1
115/1	2	-	-	-	-	-	-	-	-	-	-	-
230/1	2	-	-	-	-	-	-	-	-	-	-	-
200/3	2	-	-	-	-	-	8.1	-	8.1	8.1	8.1	8.1
230/3	2	-	-	-	-	-	7.3	-	7.3	7.3	7.3	7.3
460/3	2	-	-	-	-	-	4.3	-	4.3	4.3	4.3	4.3
575/3	2	-	-	-	-	-	3.5	-	3.5	3.5	3.5	3.5
115/1	3	-	-	-	-	-	-	-	-	-	-	-
230/1	3	-	-	-	-	-	-	-	-	-	-	-
200/3	3	-	-	-	-	-	-	-	-	11.2	11.2	11.2
230/3	3	-	-	-	-	-	-	-	-	9.5	9.5	9.5
460/3	3	-	-	-	-	-	-	-	-	5.4	5.4	5.4
575/3	3	-	-	-	-	-	-	-	-	4.6	4.6	4.6
115/1	5	-	-	-	-	-	-	-	-	-	-	-
230/1	5	-	-	-	-	-	-	-	-	-	-	-
200/3	5	-	-	-	-	-	-	-	-	-	16.5	16.5
230/3	5	-	-	-	-	-	-	-	-	-	14.3	14.3
460/3	5	-	-	-	-	-	-	-	-	-	7.8	7.8
575/3	5	-	-	-	-	-	-	-	-	-	6.5	6.5

6-446 — MODELS PDP/BDP

Wiring Diagram Selection

A. Field and Submittal Wiring Diagram Selection

Wiring in the field changes little when the brand of the controls furnished on the unit heater changes. Select correct wiring diagrams as follows:

1. Determine unit heater model and size.
2. Select control code number from Table 1.
3. Reference unit heater model in the Page Location Index with control code number and determine correct page number for single-phase or three-phase control. Single-phase wiring diagram page numbers are in the upper left of box and three-phase diagrams are in the lower right of box.
4. Wiring diagrams for unit heater accessories are listed in Table 2. Use the accessory diagrams along with the unit wiring diagrams for complete wiring instructions.

B. Service and Troubleshooting

Because internal or factory wiring may vary depending on controls manufacturer, the wiring diagrams must be selected with the series identity number when servicing or troubleshooting a unit heater control system. Wiring diagrams in this bulletin are for unit heaters manufactured after June 2003 and the series identity number is the 5th thru the 7th digits of the unit heater serial number.

EXAMPLE: Serial No. – 01121010697 has a series identity number of 101.

To select the correct wiring diagram:

1. Determine unit heater model and size from serial plate located on the side of the unit.
2. Determine the control code numbers from box marked *Control Code*, also on the serial plate.
3. Determine the *series identity number* of the unit heater, then proceed with Step 3 of Field and Submittal Wiring Diagram Selection.

Example Selection

Select correct single-phase wiring diagram for a PDP175A Control Code 11, series identity number 101.

Locate the Page Location Index which shows the page numbers for PDP and BDP units with series identity number 101 (see page iii). Select the page number where the column for the PDP175 intersects with the line for control code 11. The correct single phase wiring diagram for this unit is found on page 1 in the upper left portion of box. If the unit also had a summer/winter switch the accessory wiring diagram found on page C-2 as per Table 2, would also be required for complete wiring information.

Two-in-one Diagrams

Two wiring diagrams are furnished for each circuit configuration in this manual. Included are a connection diagram at the left for field installation and circuit schematic at the right to aid in continuity and trouble shooting.

The heavier lines in the connection diagram indicate line voltage; the lighter lines indicate low voltage. Solid lines show pre-wiring performed at the factory; dotted lines inform the installer of connections required to put the heater in operation.

Table 1
Control Code Descriptions

Control Code Number	Description
11,12,13,14	Single-Stage, Standing Pilot, 100% Shut-Off, Natural Gas
81,82,91,92	Single-Stage, Standing Pilot, 100% Shut-Off, Propane Gas
25,26	Two-Stage, Standing Pilot, 100% Shut-Off, Natural Gas
83,84	Two-Stage, Standing Pilot, 100% Shut-Off, Propane Gas
30,31,32,33	Single-Stage, Intermittent Pilot Ignition, 100% Shut-Off with Continuous Retry, Natural Gas
85,86,93,94	Single-Stage, Intermittent Pilot Ignition, 100% Shut-Off with Continuous Retry, Propane Gas
59,60	Mechanical Modulation with Automatic Pilot Ignition, Non-100% Shut-Off, Natural Gas, BDP Only
89,90	Mechanical Modulation with Automatic Pilot Ignition, Non-100% Shut-Off, Propane Gas, BDP Only
63,64	Two-Stage, Intermittent Pilot Ignition, 100% Shut-Off with Continuous Retry, Natural Gas
87,88	Two-Stage, Intermittent Pilot Ignition, 100% Shut-Off with Continuous Retry, Propane Gas

Table 2
Accessory Wiring Diagram Page Location Index ①

Page	Accessory
C-1	Energy-Saver Kit
C-2	Summer/Winter Switch

① See paragraph A, step 4 under "Wiring Diagram Selection".

6-446 — MODELS PDP/BDP

Models PDP or BDP Page Location Index ①

Control Code	Model Size (series identity 101) ①											
	30	50	75	100	125	150	175	200	250	300	350	400
11 or 12		1	1	1	1	1	1	1	1	1	3	3
13 or 14		2	2	2	2	2	2	2	2	2	4	4
25 or 26	5	5	5	5	5	5	5	5	7	7	7	7
30 or 31		6	6	6	6	6	6	6	8	8	8	8
32 or 33		9	9	9	9	9	9	9	10	10	10	10
59 or 60			11	11	11	11	11	11	12	12		
63 or 64	15	15	15	15	15	15	15	15	16	16	15	15
81 or 82		16	16	16	16	16	16	16	17	17	16	16
83 or 84	5	5	5	5	5	5	5	5	2	2	7	7
85 or 86		6	6	6	6	6	6	6	6	6	6	6
87 or 88	15	15	15	15	15	15	15	15	10	10	10	10
89 or 90		16	16	16	16	16	16	16	16	16	15	15
91 or 92			11	11	11	11	11	11	12			
93 or 94			12	12	12	12	12	12				
			17	17	17	17	17	17	17	17		
			19	19	19	19	19	19	19	19	19	19

Control Code	Model Size (series identity 102) ①											
	30	50	75	100	125	150	175	200	250	300	350	400
11 or 12	1	1	1	1	1	1	1	1	3	3	3	3
13 or 14		2	2	2	2	2	2	2	4	4	4	4
25 or 26			17	17	17	17	17	17	18	18	18	18
30 or 31	9	9	9	9	9	9	9	9	10	10	9	9
32 or 33		10	10	10	10	10	10	10	10	10	10	10
59 or 60			13	13	13	13	13	13	19	19	19	19
63 or 64	20	20	20	20	20	20	20	20	14	14	13	13
81 or 82	1	1	1	1	1	1	1	1	21	21	3	3
83 or 84		2	2	2	2	2	2	2	2	4	4	4
85 or 86	9	9	9	9	9	9	9	9	10	10	9	9
87 or 88	20	20	20	20	20	20	20	20	10	10	20	20
89 or 90		10	10	10	10	10	10	10	21	21	13	13
91 or 92			13	13	13	13	13	13	14	14	13	13
93 or 94			14	14	14	14	14	14	14	14	14	14
			17	17	17	17	17	17	17	17	18	18
			19	19	19	19	19	19	19	19	19	19

Control Code	Model Size (series identity 103) ①											
	30	50	75	100	125	150	175	200	250	300	350	400
11 or 12									3	3	3	3
13 or 14									4	4	4	4
25 or 26									18	18	18	18
30 or 31	9	9	9	9	9	9	9	9	10	10	9	9
32 or 33		10	10	10	10	10	10	10	10	10	10	10
59 or 60			19	19	19	19	19	19	19	19	19	19
63 or 64												
81 or 82									3	3	3	3
83 or 84									4	4	4	4
85 or 86	9	9	9	9	9	9	9	9	10	10	9	9
87 or 88		10	10	10	10	10	10	10	10	10	10	10
89 or 90												
91 or 92												
93 or 94			19	19	19	19	19	19	19	19	19	19

① Cell format represents single phase or three phase power as shown in the following example.

1-Ph
3-Ph

UNIT HEATER WIRING DIAGRAM

Wiring Legend	
Factory	Line 24V
Field	- - - - -
Wire Nut	○

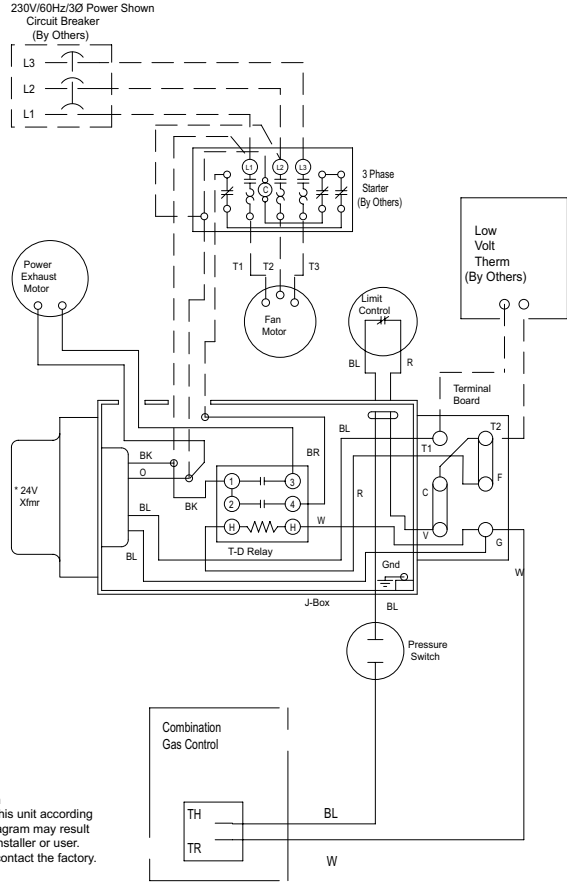

Caution
Failure to wire this unit according to this wiring diagram may result in injury to the installer or user. For deviations contact the factory.

Note to installer:
Attach this diagram near heater.

All wiring must comply with national electric code and all local codes.

All components must agree with their respective power source.

Use 105° wire for replacements.

Some models may have limit control to pressure switch wire routed outside of J-box.

* Alternate Xfmr
Primary Xfmr Wires
230V/60Hz/1Ø-BK & Y (OR O)
200V/60Hz/1Ø-BK & R
Wire nut the wire not used.

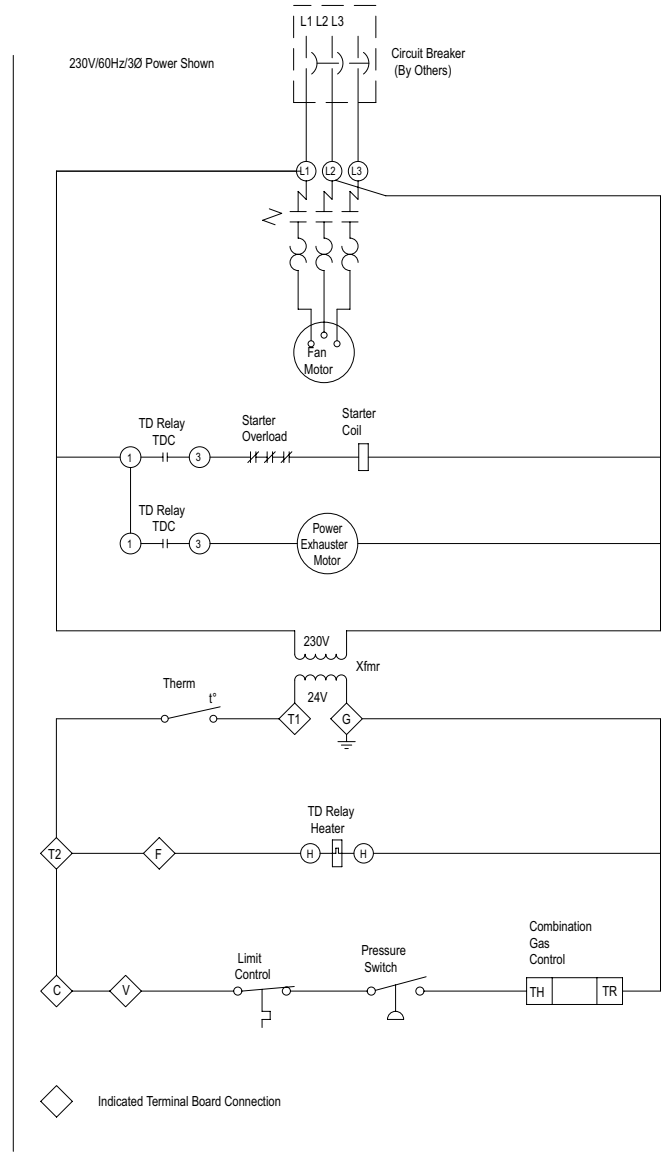

◇ Indicated Terminal Board Connection

UNIT HEATER WIRING DIAGRAM

WIRING LEGEND	
FACTORY	LINE
FIELD	24V.
WIRE NUT	

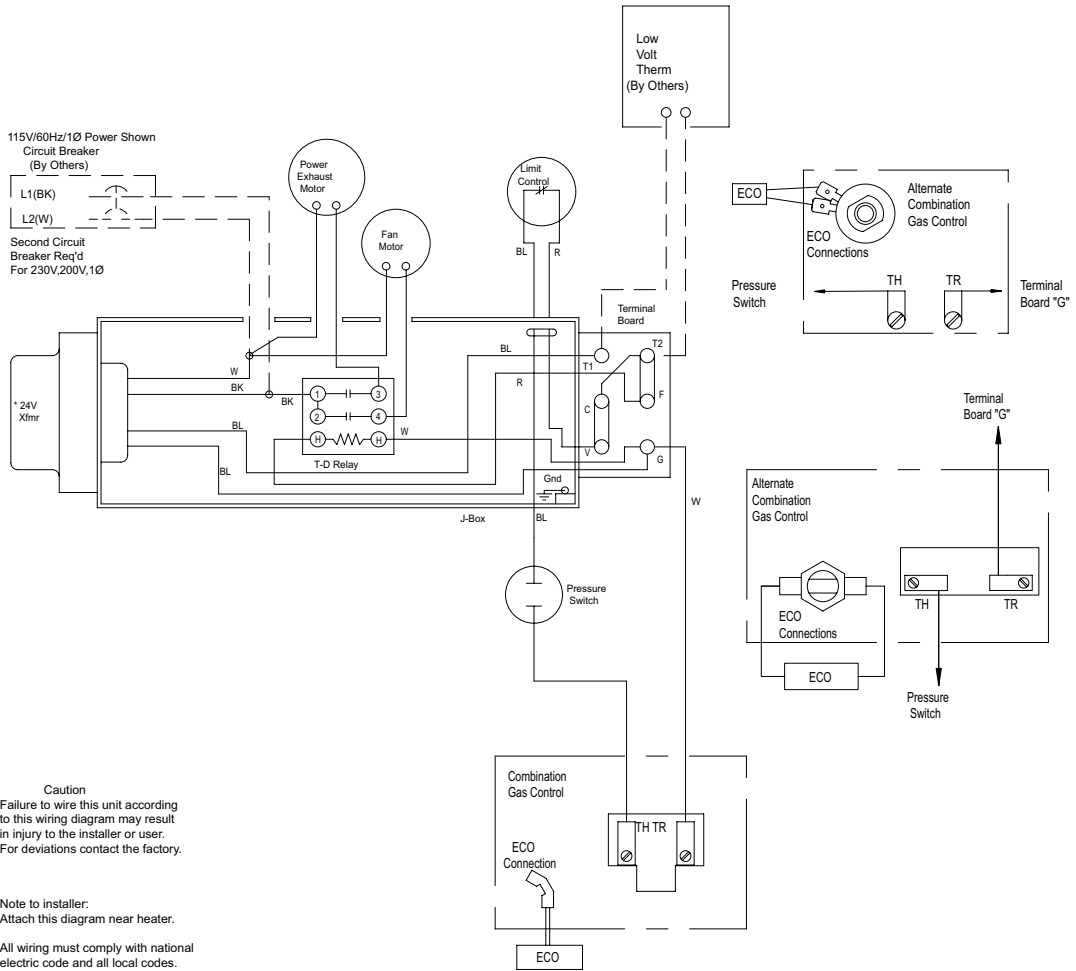

Caution
Failure to wire this unit according to this wiring diagram may result in injury to the installer or user. For deviations contact the factory.

Note to installer:
Attach this diagram near heater.

All wiring must comply with national electric code and all local codes.

All components must agree with their respective power source.

Use 105° wire for replacements.

Some models may have limit control to pressure switch wire routed outside of J-box

* Alternate Xfmr.
Primary Xfmr Wires
230V/60Hz/1Ø-BK & Y (OR O)
200V/60Hz/1Ø-BK & R
Wire nut the wire not used.

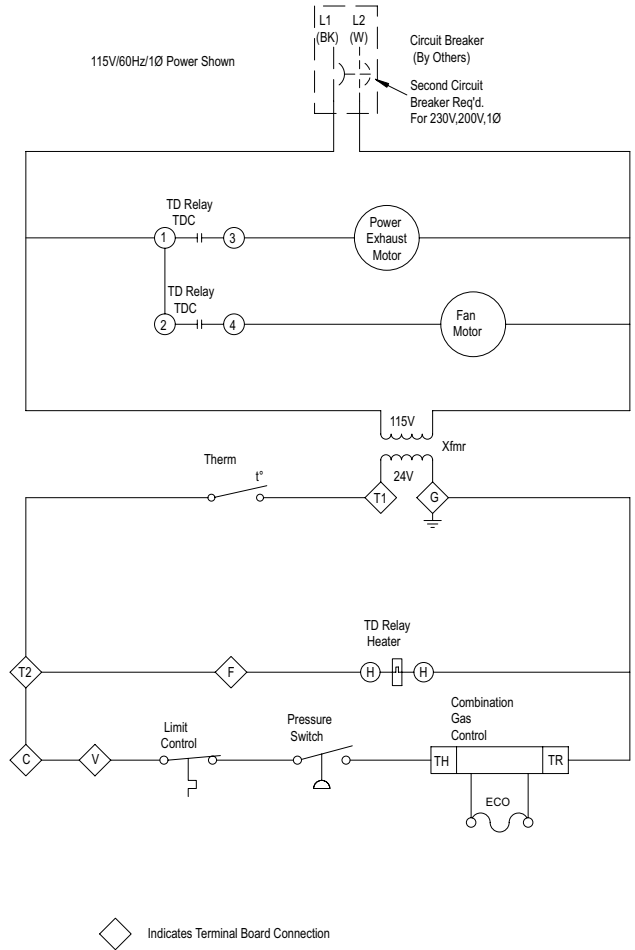

◇ Indicates Terminal Board Connection

UNIT HEATER WIRING DIAGRAM

Wiring Legend	
Factory	Line 24V
Field	---
Wire Nut	⊕

230V/60Hz/3Ø Power Shown
Circuit Breaker
(By Others)

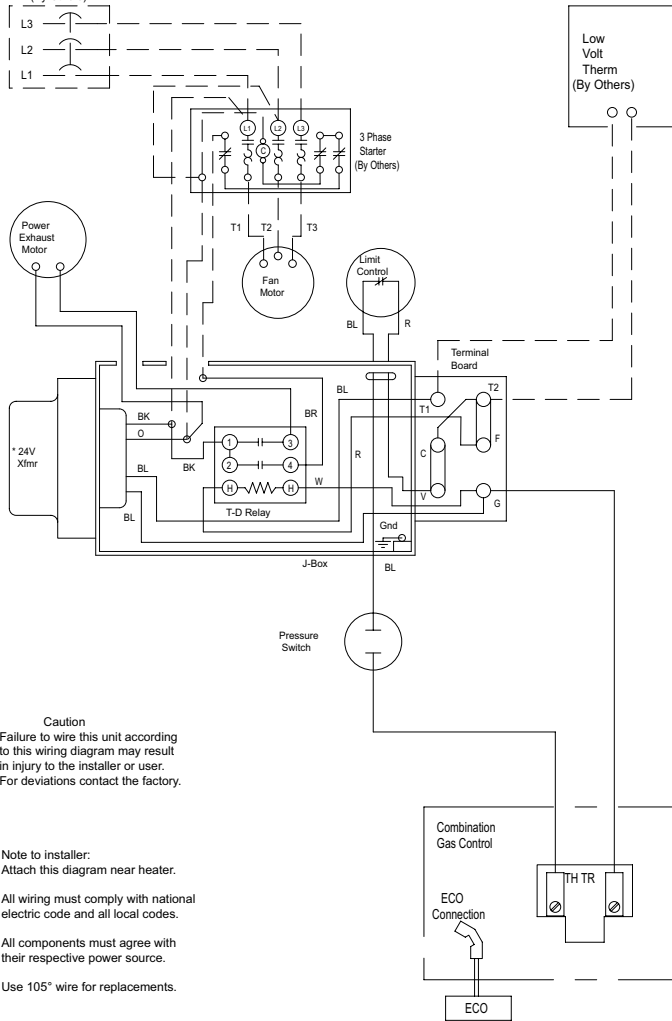

Caution
Failure to wire this unit according to this wiring diagram may result in injury to the installer or user. For deviations contact the factory.

Note to installer:
Attach this diagram near heater.

All wiring must comply with national electric code and all local codes.

All components must agree with their respective power source.

Use 105° wire for replacements.

Some models may have limit control to pressure switch wire routed outside of J-box.

* Alternate Xfmr.
Primary Xfmr Wires
230V/60Hz/1Ø-BK & Y (OR O)
200V/60Hz/1Ø-BK & R
Wire nut the wire not used.

230V/60Hz/3Ø Power Shown

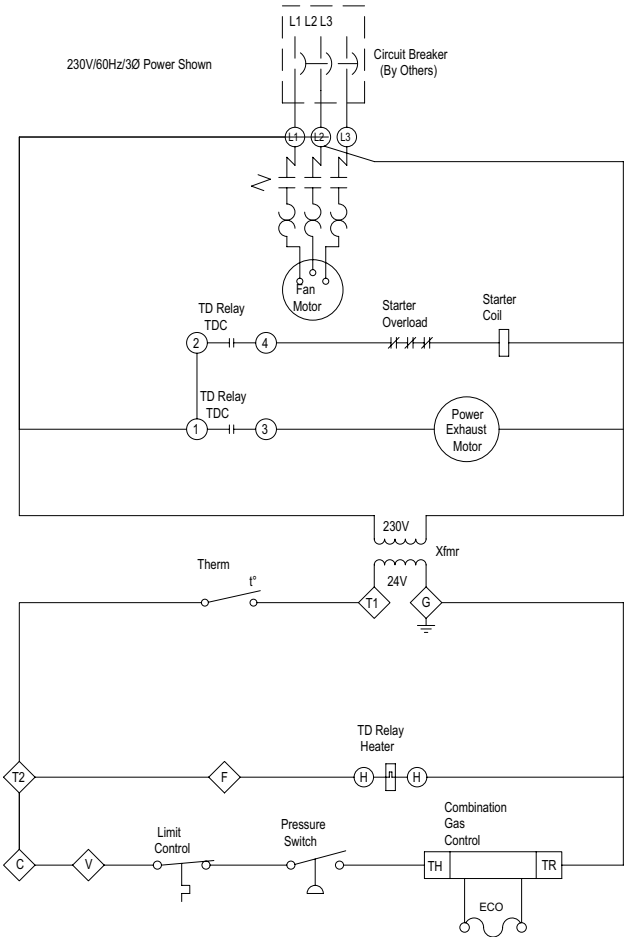

◇ Indicates Terminal Board Connection

UNIT HEATER WIRING DIAGRAM

Wiring Legend	
Factory	Line 24V.
Field	
Wire Nut	

230V/60Hz/3Ø Power Shown
Circuit Breaker
(By Others)

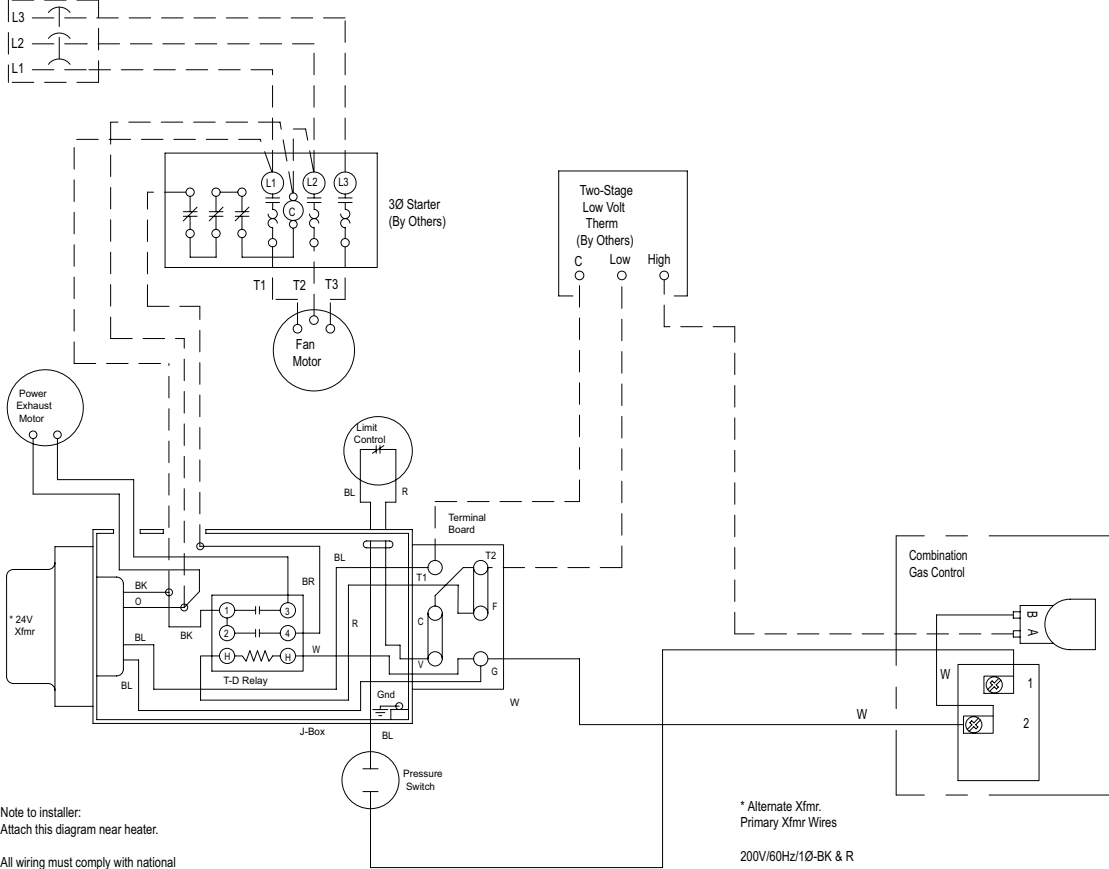

Note to installer:
Attach this diagram near heater.

All wiring must comply with national
electric code and all local codes.

All components must agree with
their respective power source.

Use 105°C wire for replacements.

Some models may have limit control
to pressure switch wire routed outside
of J-box.

Caution
Failure to wire this unit according
to this wiring diagram may result
in injury to the installer or user.
For deviations contact the factory.

* Alternate Xfmr.
Primary Xfmr Wires

200V/60Hz/1Ø-BK & R

230V/60Hz/1Ø-BK & Y (OR O)

Wire nut the wire not used.

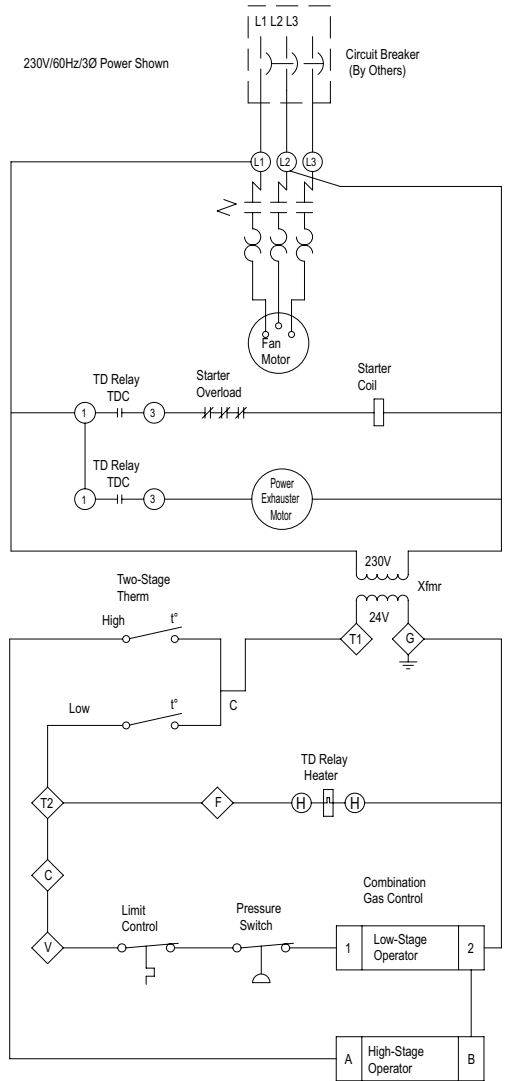

◇ Indicated Terminal Board Connection

UNIT HEATER WIRING DIAGRAM

Wiring Legend	
Factory	Line
Field	24V.
Wire Nut	

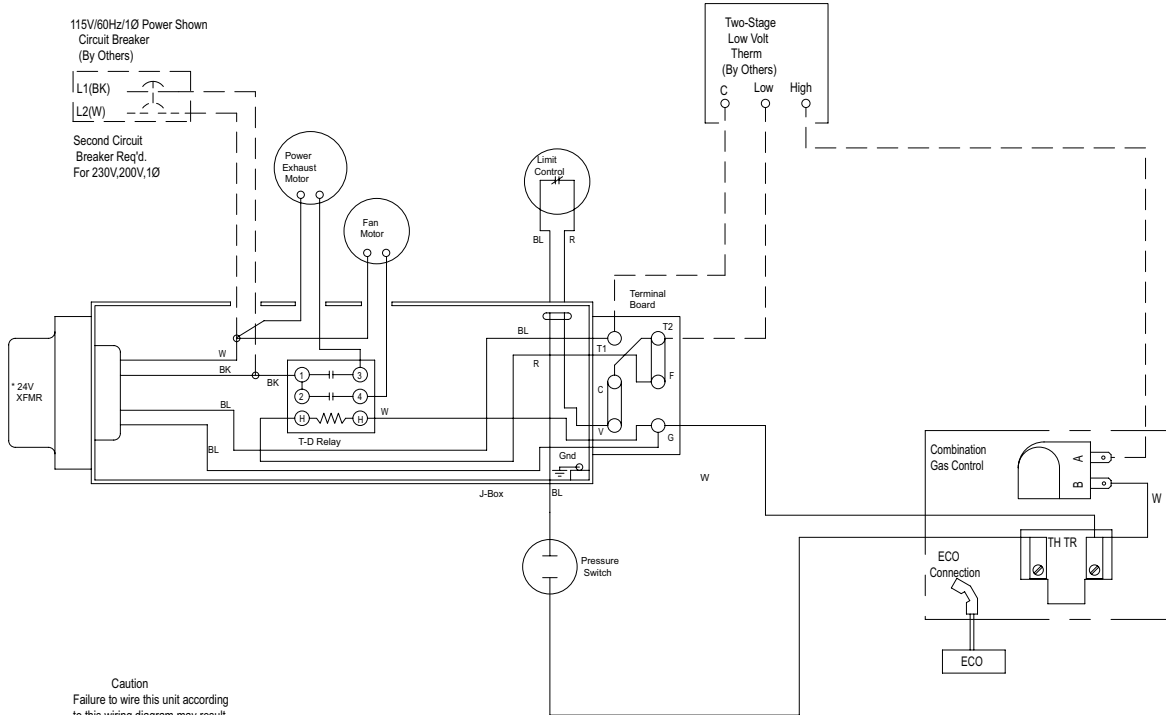

Caution
Failure to wire this unit according to this wiring diagram may result in injury to the installer or user. For deviations contact the factory.

Note to installer:
Attach this diagram near heater.

All wiring must comply with national electric code and all local codes.

All components must agree with their respective power source.

Use 105°C wire for replacements.

Some models may have limit control to pressure switch wire routed outside of J-box.

* Alternate Xfmr.
Primary Xfmr Wires
230V/60Hz/1Ø-BK & Y (OR O)
200V/60Hz/1Ø-BK & R
Wire nut the wire not used.

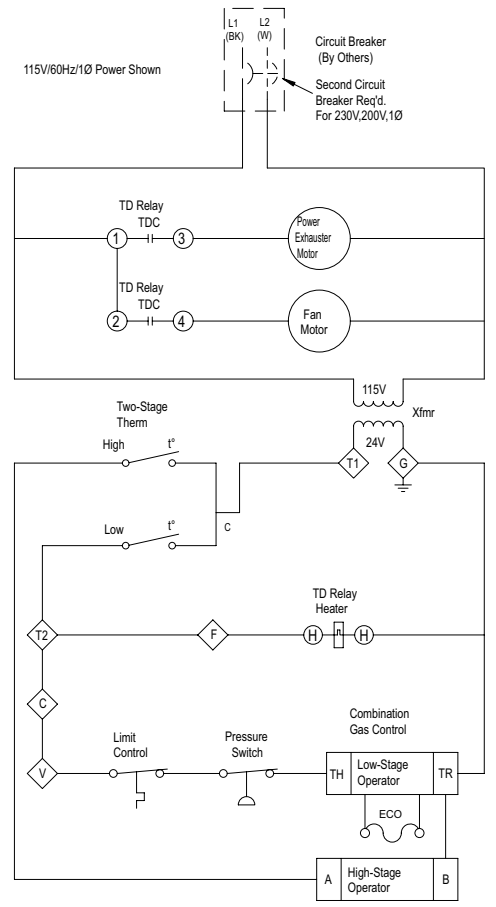

◇ Indicates Terminal Board Connection

Wiring Legend		
Factory	Line	24V.
Field		
Wire Nut		

UNIT HEATER WIRING DIAGRAM

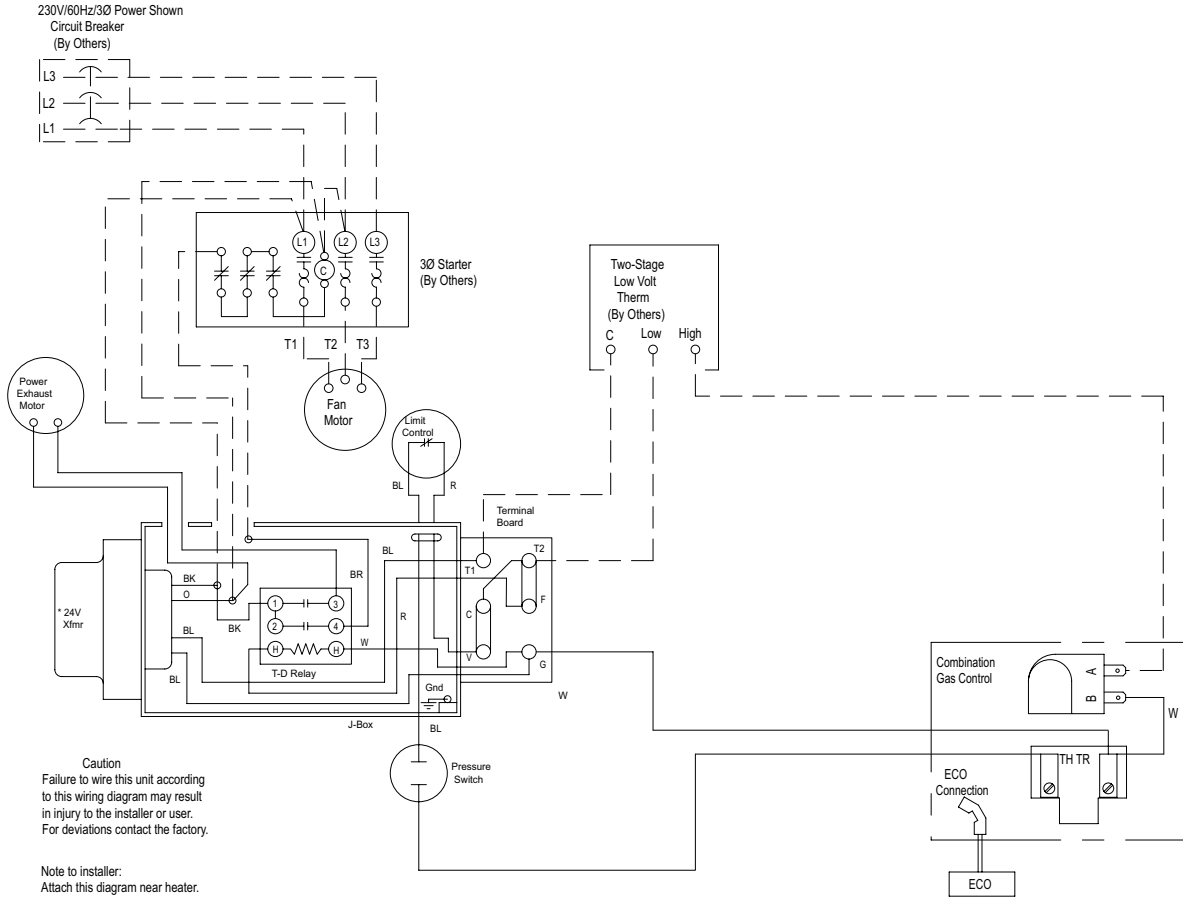

Caution
Failure to wire this unit according to this wiring diagram may result in injury to the installer or user. For deviations contact the factory.

Note to installer:
Attach this diagram near heater.

All wiring must comply with national electric code and all local codes.

All components must agree with their respective power source.

Use 105°C wire for replacements.

Some models may have limit control to pressure switch wire routed outside of J-box.

* Alternate Xfmr.
Primary Xfmr Wires
230V/60Hz/1Ø-BK & Y (OR O)
200V/60Hz/1Ø-BK & R
Wire nut the wire not used.

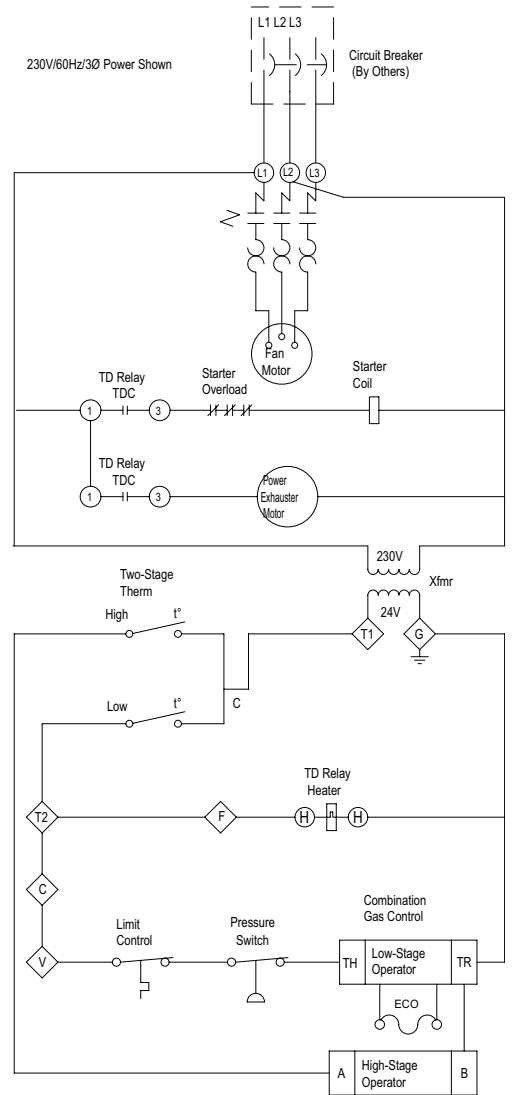

◇ Indicated Terminal Board Connection

UNIT HEATER WIRING DIAGRAM

WIRING LEGEND	
FACTORY	LINE
FIELD	24V.
WIRE NUT	

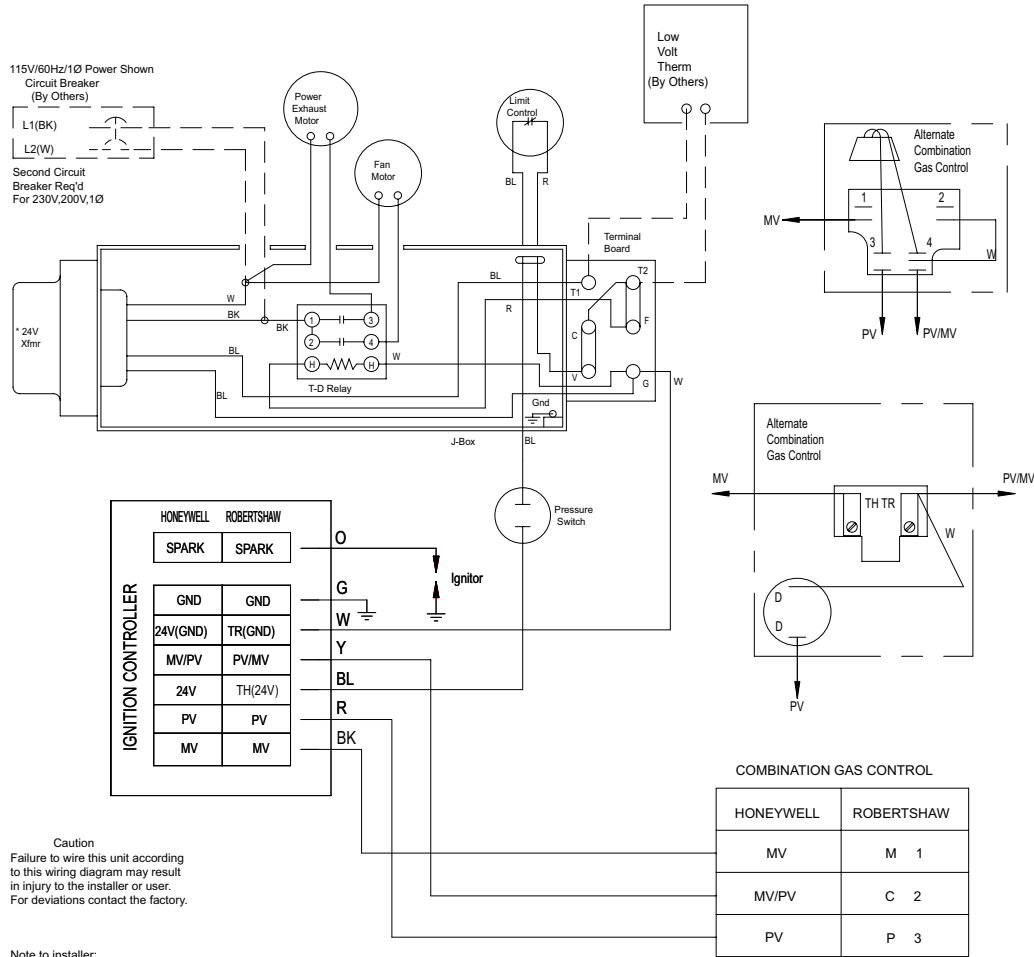

Caution
Failure to wire this unit according to this wiring diagram may result in injury to the installer or user. For deviations contact the factory.

Note to installer:
Attach this diagram near heater.

All wiring must comply with national electric code and all local codes.

All components must agree with their respective power source.

Use 105" wire for replacements.

Some models may have limit control to pressure switch wire routed outside of J-box.

* Alternate Xfmr.
Primary Xfmr Wires
230V/60Hz/1Ø-BK & Y (OR O)
200V/60Hz/1Ø-BK & R
Wire nut the wire not used.

115V/60Hz/1Ø Power Shown

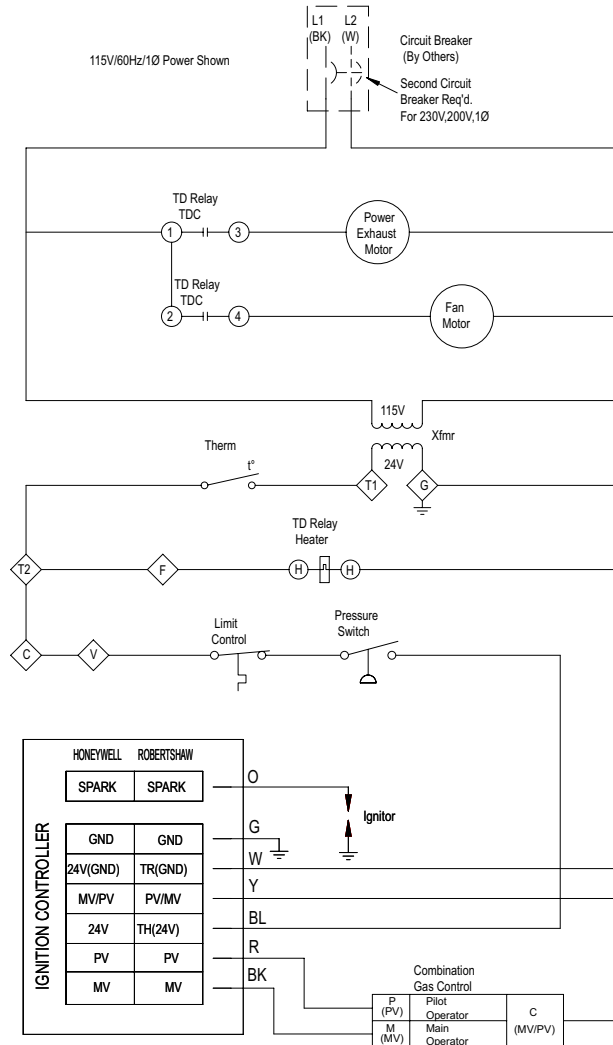

◊ Indicates Terminal Board Connection

UNIT HEATER WIRING DIAGRAM

Wiring Legend	
Factory	Line 24V
Field	---
Wire Nut	○

230V/60Hz/3Ø Power Shown
Circuit Breaker
(By Others)

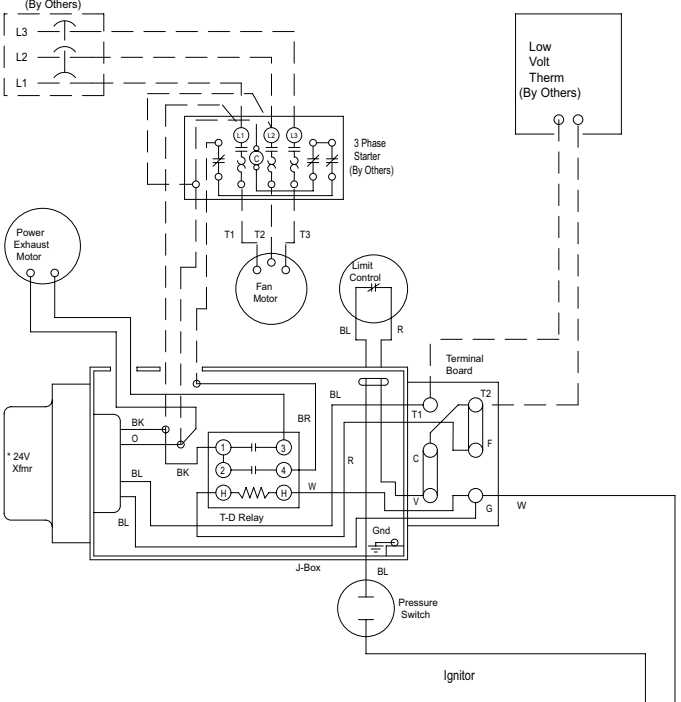

Caution
Failure to wire this unit according to this wiring diagram may result in injury to the installer or user. For deviations contact the factory.

Note to installer:
Attach this diagram near heater.

All wiring must comply with national electric code and all local codes.

All components must agree with their respective power source.

Use 105° wire for replacements.

Some models may have limit control to pressure switch wire routed outside of J-box.

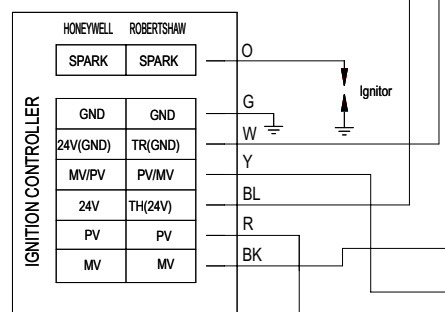

* Alternate Xfmr.
Primary Xfmr Wires
230V/60Hz/1Ø-BK & Y (OR O)
200V/60Hz/1Ø-BK & R
Wire nut the wire not used.

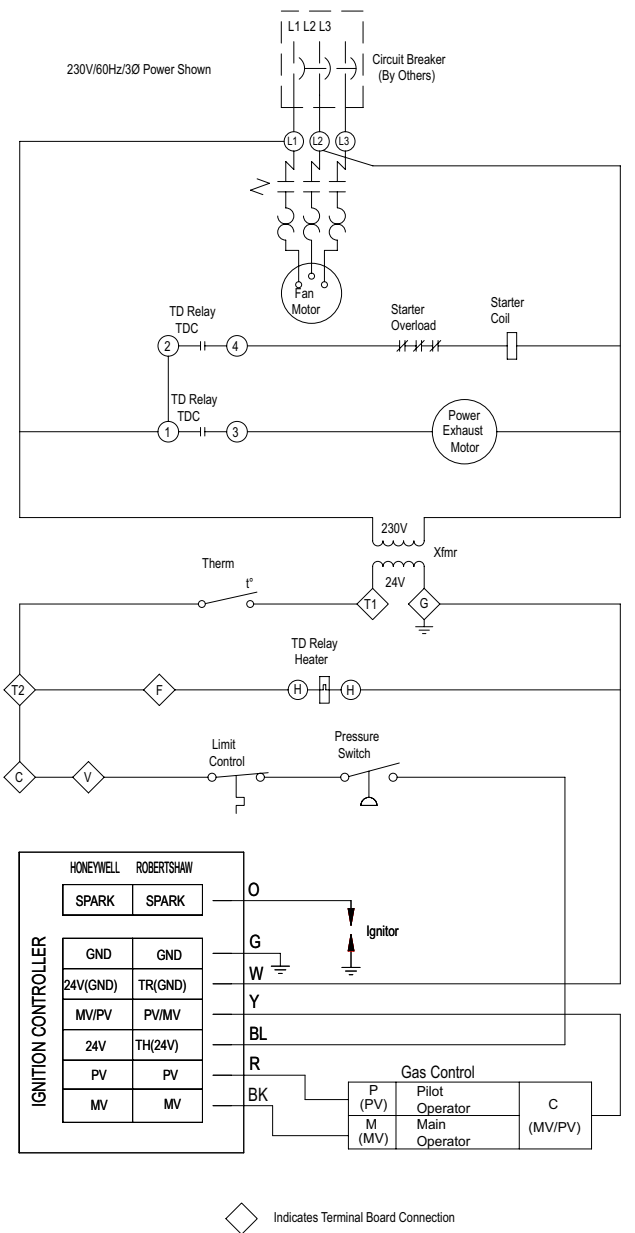
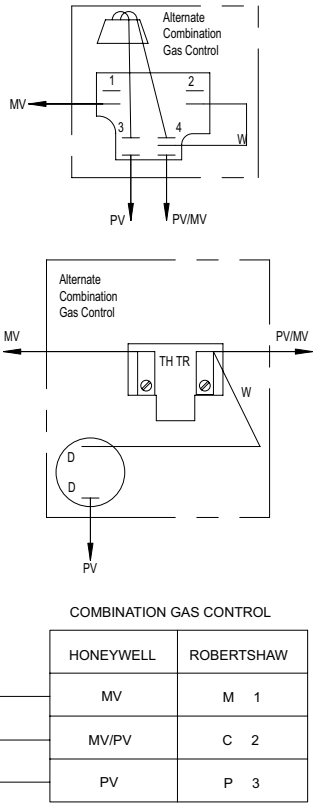

◇ Indicates Terminal Board Connection

UNIT HEATER WIRING DIAGRAM

WIRING LEGEND		
FACTORY	LINE	24V
FIELD	---	---
WIRE NUT	○	---

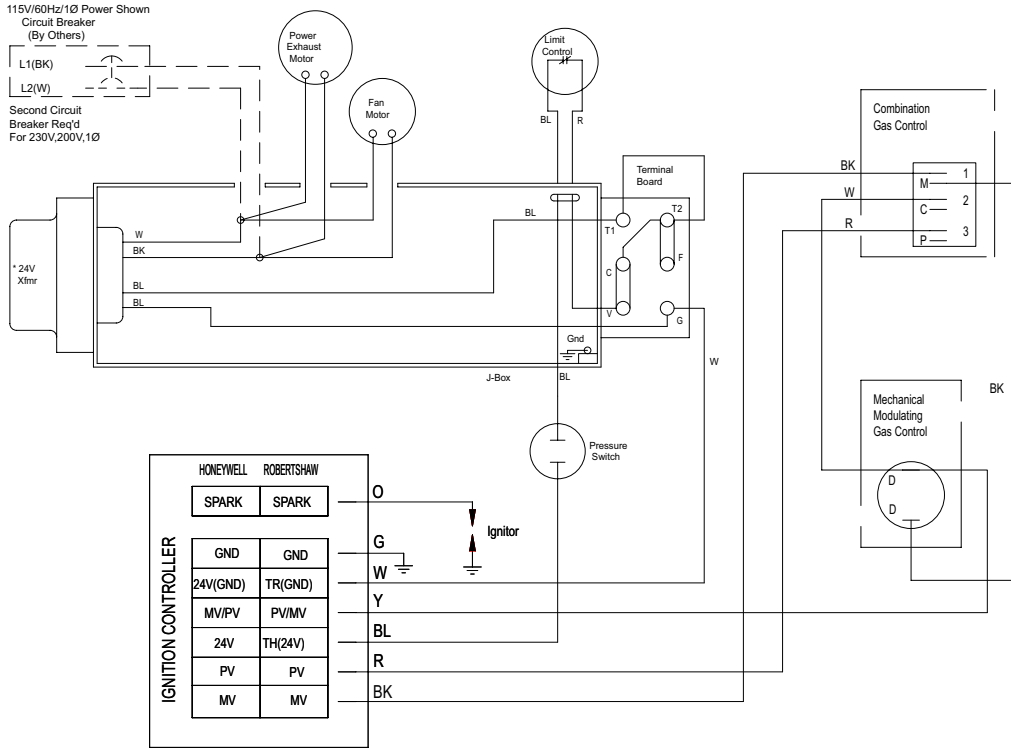

Caution
Failure to wire this unit according to this wiring diagram may result in injury to the installer or user. For deviations contact the factory.

Note to installer:
Attach this diagram near heater.

All wiring must comply with national electric code and all local codes.

All components must agree with their respective power source.

Use 105° wire for replacements.

Some models may have limit control to pressure switch wire routed outside of J-box.

* Alternate Xfmr.
Primary Xfmr Wires
230V/60Hz/1Ø-BK & Y (OR O)
200V/60Hz/1Ø-BK & R
Wire nut the wire not used.

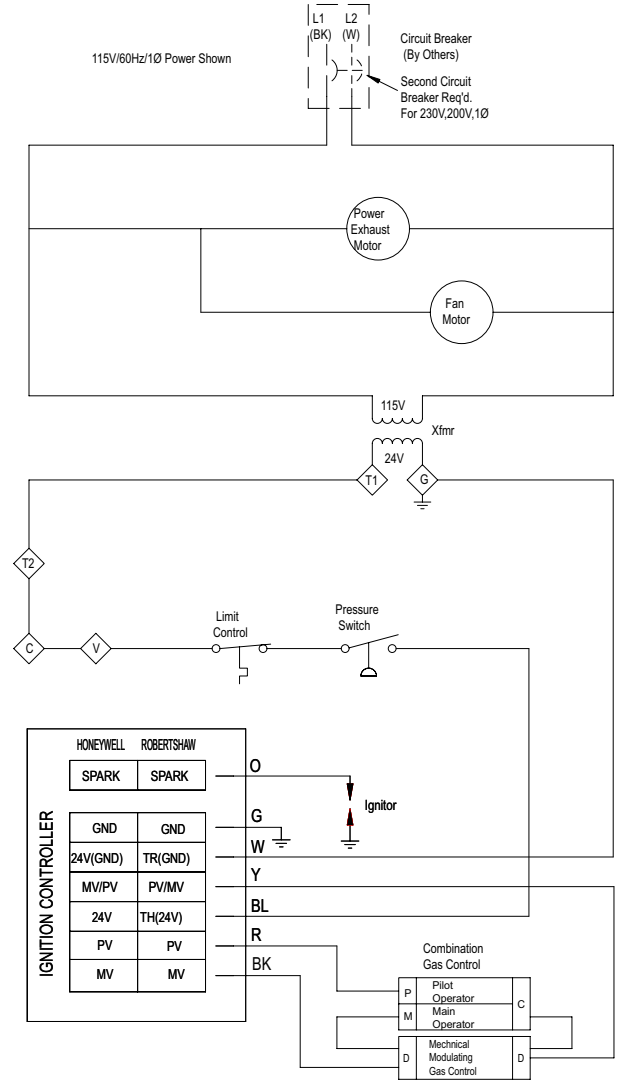

◇ Indicates Terminal Board Connection

UNIT HEATER WIRING DIAGRAM

Wiring Legend	
Factory	Line 24V.
Field	---
Wire Nut	○

230V/60Hz/3Ø Power Shown
Circuit Breaker (By Others)

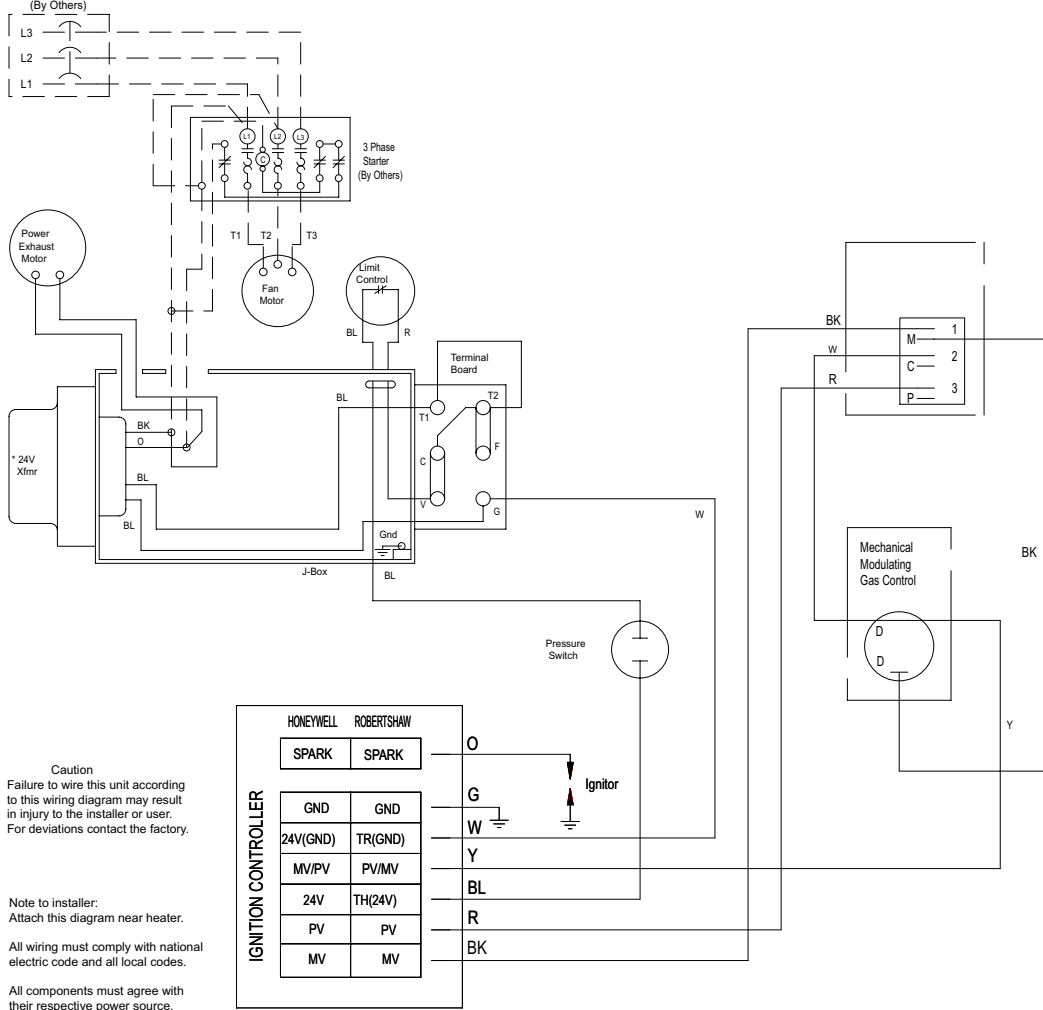

Caution
Failure to wire this unit according to this wiring diagram may result in injury to the installer or user. For deviations contact the factory.

Note to installer:
Attach this diagram near heater.

All wiring must comply with national electric code and all local codes.

All components must agree with their respective power source.

Use 105° wire for replacements.

Some models may have limit control to pressure switch wire routed outside of J-box.

* Alternate Xfmr.
Primary Xfmr Wires
230V/60Hz/1Ø-BK & Y (OR O)
200V/60Hz/1Ø-BK & R
Wire nut the wire not used.

230V/60Hz/3Ø Power Shown

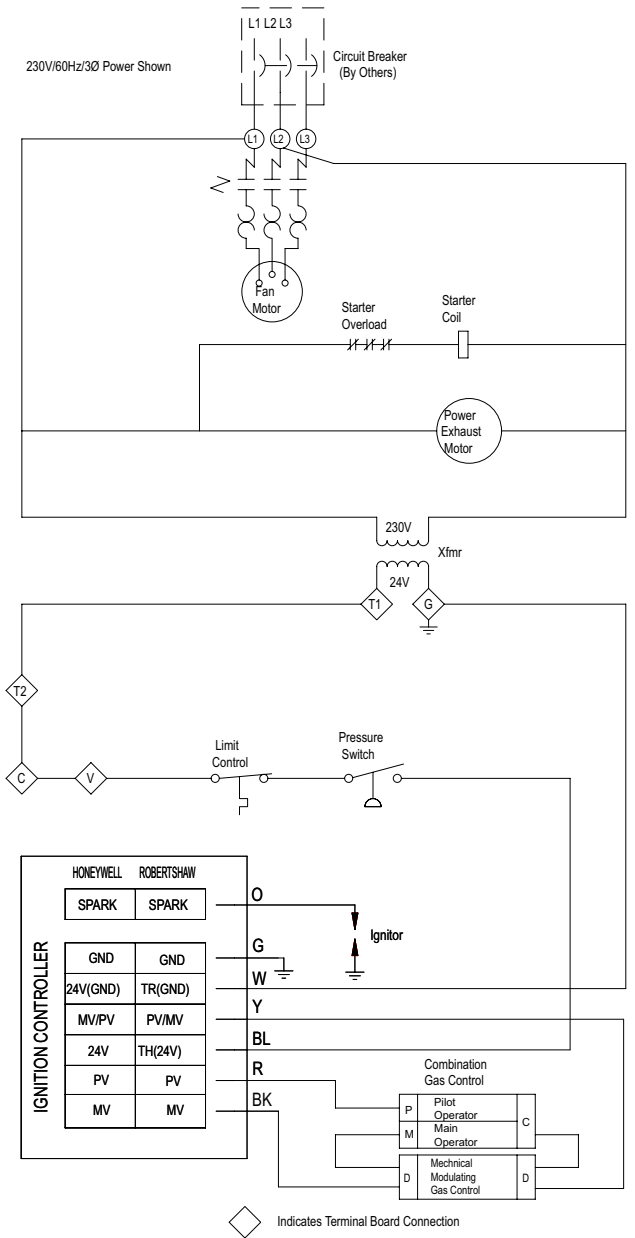

◇ Indicates Terminal Board Connection

UNIT HEATER WIRING DIAGRAM

WIRING LEGEND		
FACTORY	LINE	24V
FIELD	---	---
WIRE NUT	○	---

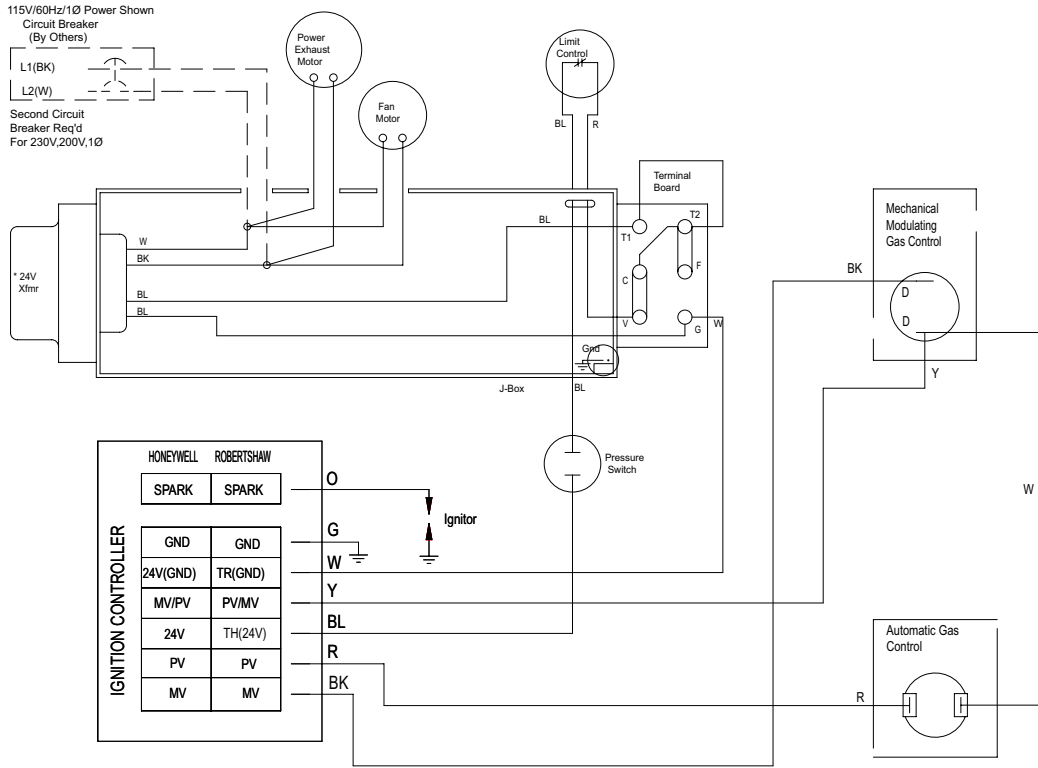

Caution
Failure to wire this unit according to this wiring diagram may result in injury to the installer or user. For deviations contact the factory.

Note to installer:
Attach this diagram near heater.

All wiring must comply with national electric code and all local codes.

All components must agree with their respective power source.

Use 105" wire for replacements.

Some models may have limit control to pressure switch wire routed outside of J-box

* Alternate Xfmr.
Primary Xfmr Wires
230V/60Hz/1Ø-BK & Y (OR O)
200V/60Hz/1Ø-5K & R
Wire nut the wire not used.

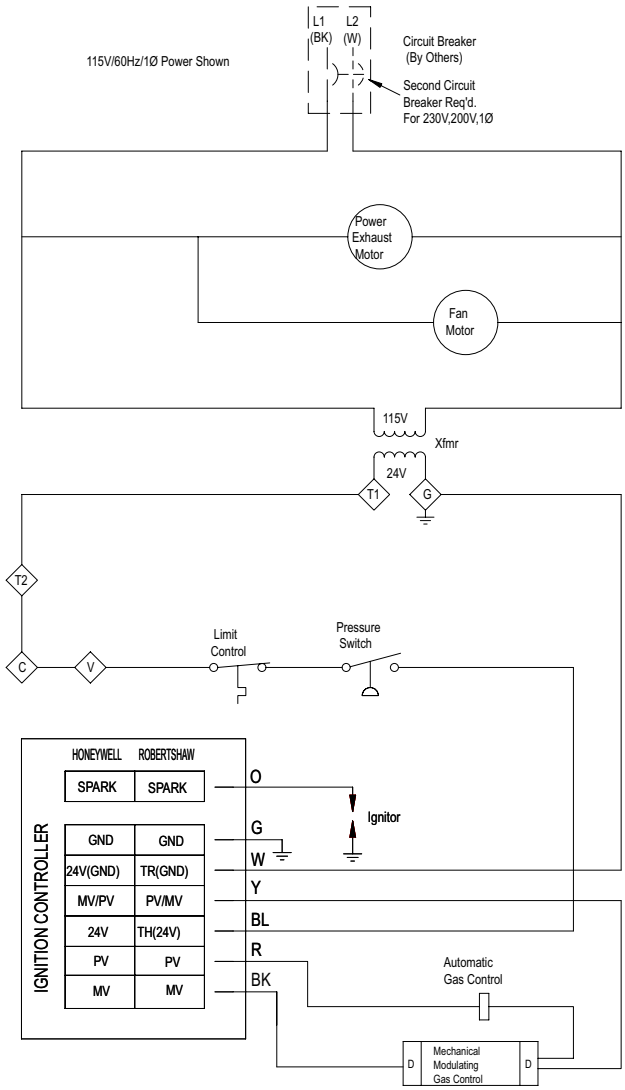

◇ Indicates Terminal Board Connection

UNIT HEATER WIRING DIAGRAM

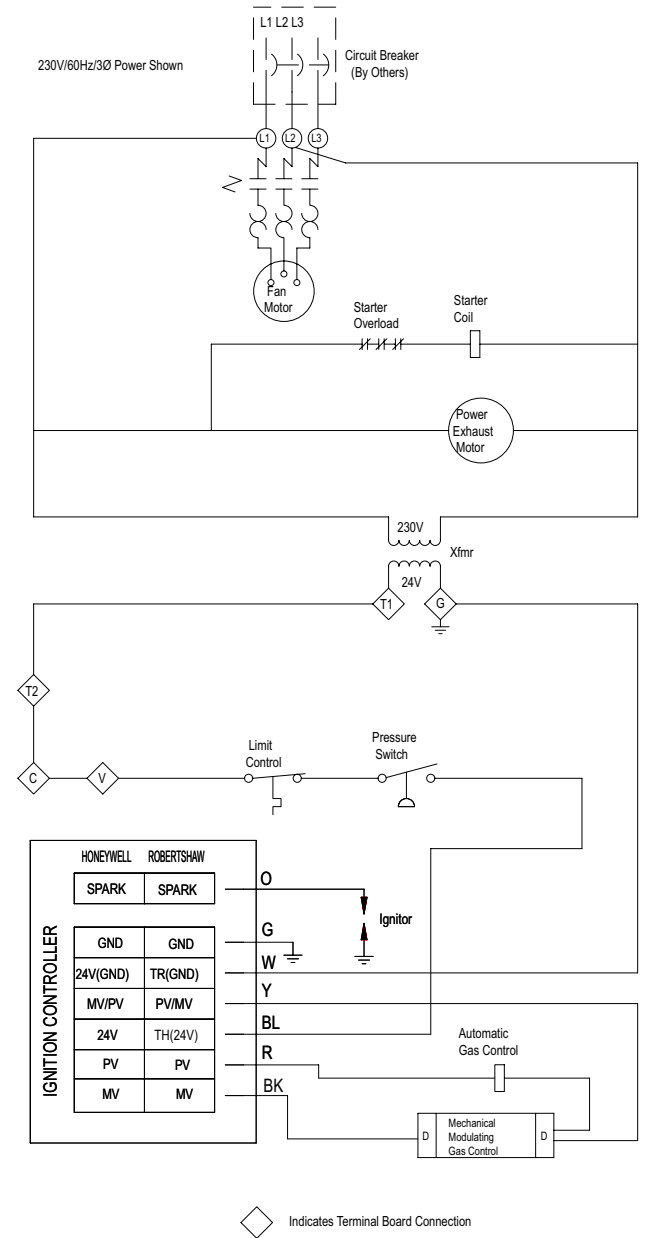

◇ Indicates Terminal Board Connection

Wiring Legend	
Factory	Line 24V
Field	---
Wire Nut	—○—

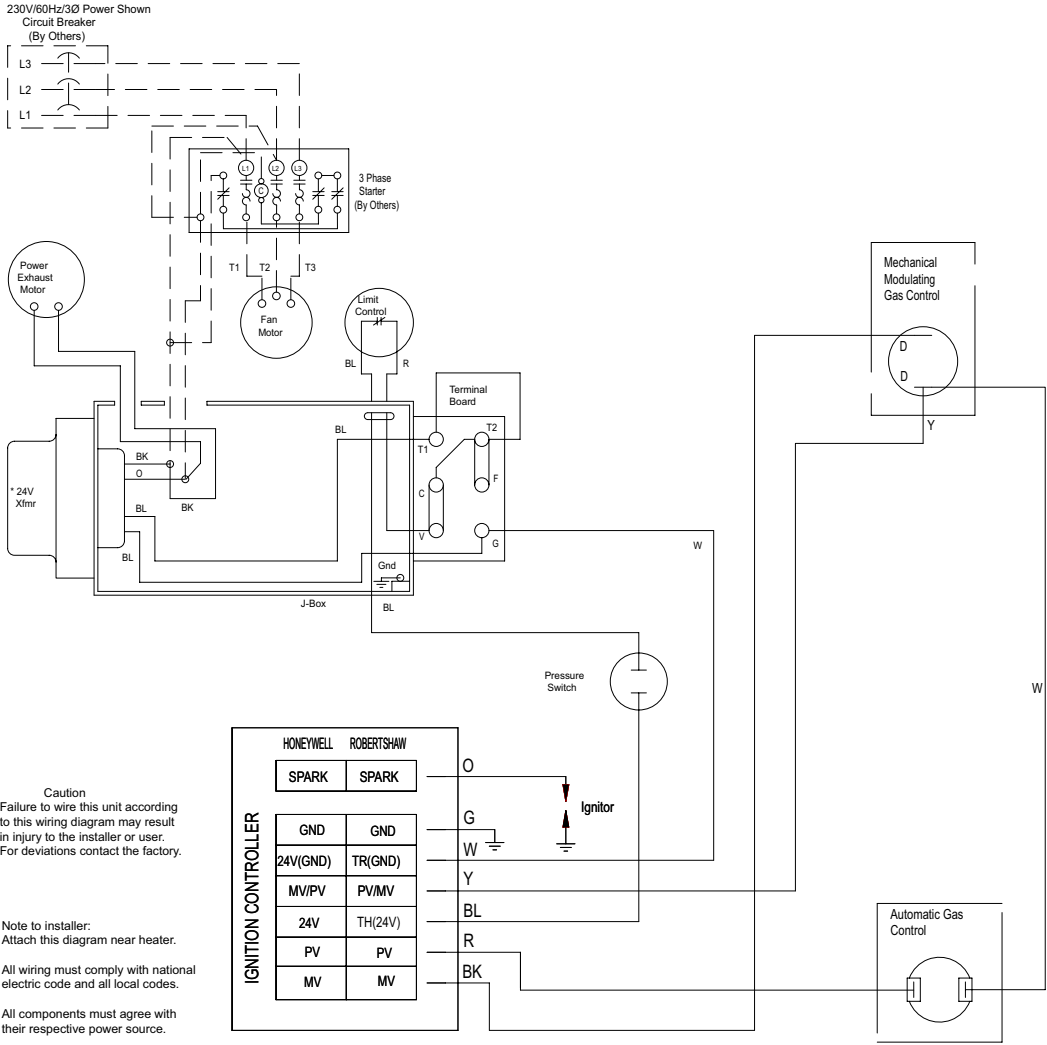

* Alternate Xfmr.
 Primary Xfmr Wires
 230V/60Hz/1Ø-BK & Y (OR O)
 200V/60Hz/1Ø-BK & R
 Wire nut the wire not used.

Caution
 Failure to wire this unit according to this wiring diagram may result in injury to the installer or user. For deviations contact the factory.

Note to installer:
 Attach this diagram near heater.

All wiring must comply with national electric code and all local codes.

All components must agree with their respective power source.

Use 105° wire for replacements.

Some models may have limit control to pressure switch wire routed outside of J-box.

5H78233C4 REV A

Mechanical Modulation, Intermittent Pilot Ignition, 100% Shut-Off with Continuous Retry, Three-Phase.

UNIT HEATER WIRING DIAGRAM

WIRING LEGEND	
FACTORY	LINE
FIELD	24V.
WIRE NUT	

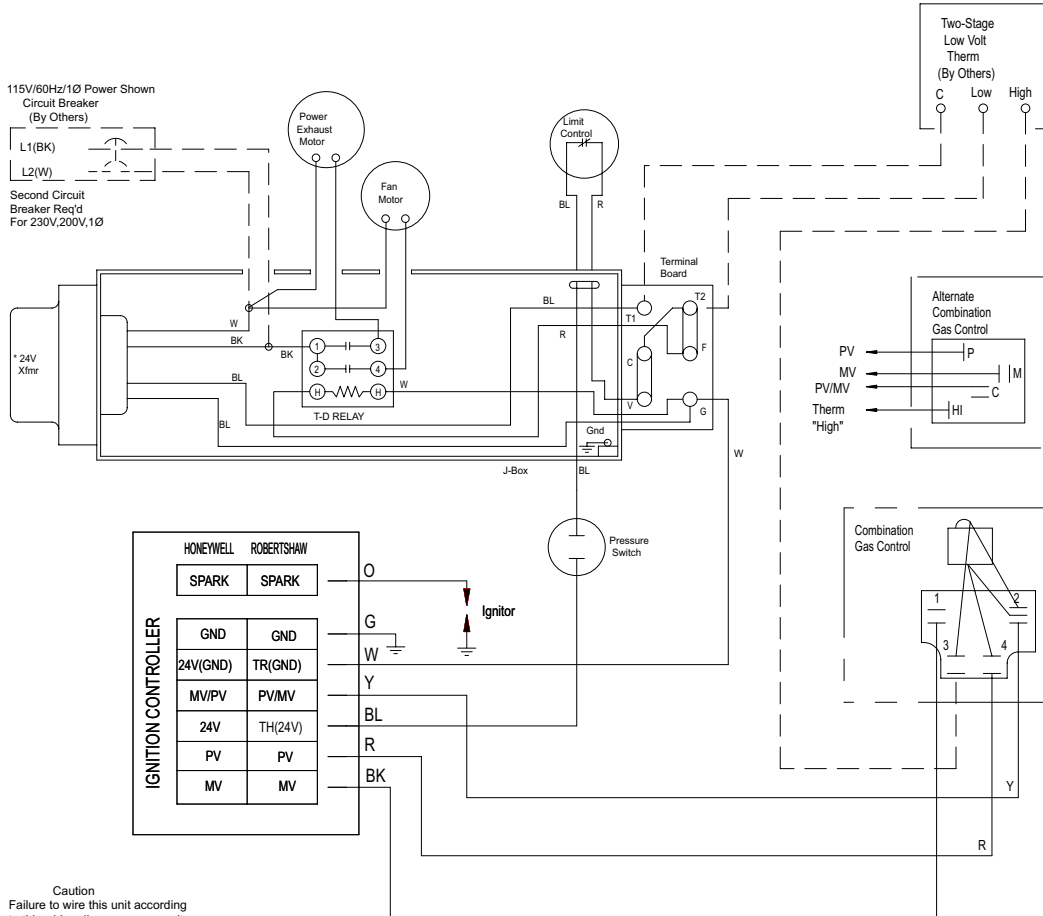

IGNITION CONTROLLER	HONEWELL	ROBERTSHAW	Terminal
	SPARK	SPARK	
GND	GND	G	
24V(GND)	TR(GND)	W	
MV/PV	PV/MV	Y	
24V	TH(24V)	BL	
PV	PV	R	
MV	MV	BK	

Caution
Failure to wire this unit according to this wiring diagram may result in injury to the installer or user. For deviations contact the factory.

Note to installer:
Attach this diagram near heater.

All wiring must comply with national electric code and all local codes.

All components must agree with their respective power source.

Use 105° wire for replacements.

Some models may have limit control to pressure switch wire routed outside of J-box.

* Alternate Xfmr
Primary Xfmr Wires
230V/60Hz/1Ø-BK & Y (OR O)
200V/60Hz/1Ø-BK & R
Wire nut the wire not used.

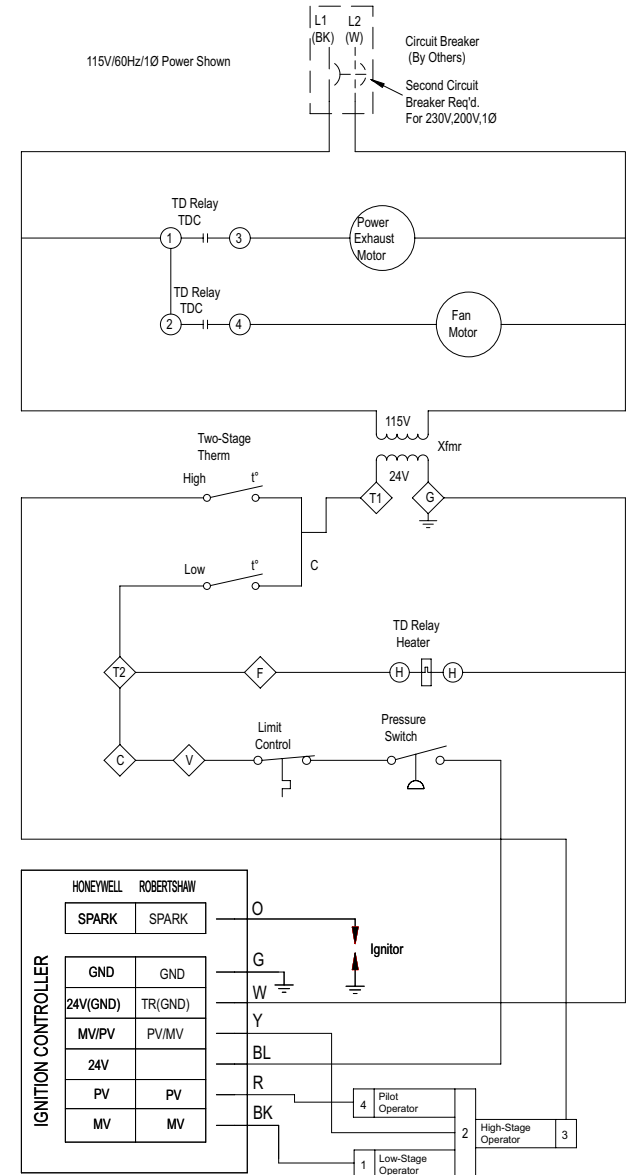

IGNITION CONTROLLER	HONEWELL	ROBERTSHAW	Terminal
	SPARK	SPARK	
GND	GND	G	
24V(GND)	TR(GND)	W	
MV/PV	PV/MV	Y	
24V		BL	
PV	PV	R	
MV	MV	BK	

◇ Indicates Terminal Board Connection

UNIT HEATER WIRING DIAGRAM

Wiring Legend	
Factory	Line
Field	24V
Wire Nut	

230V/60Hz/3Ø Power Shown
Circuit Breaker (By Others)

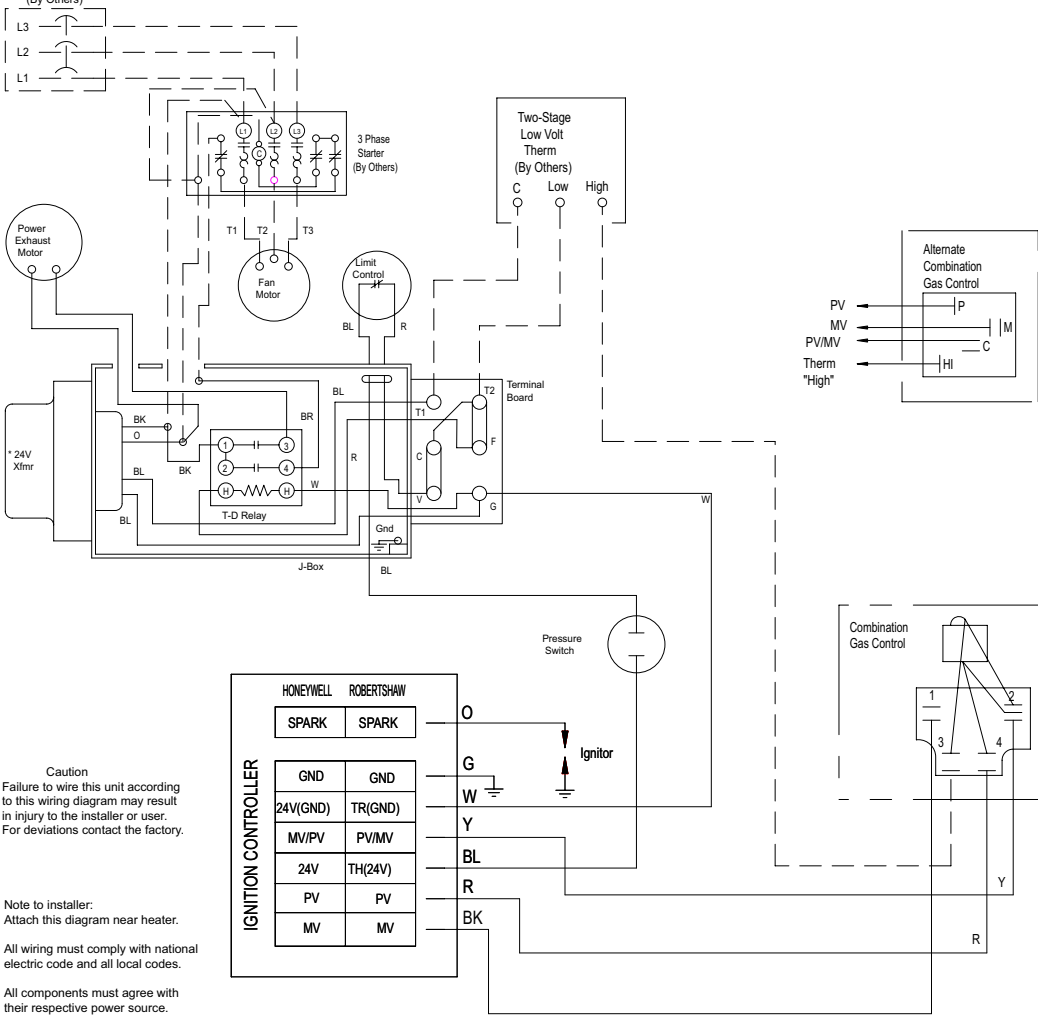

HONEYWELL		ROBERTSHAW	
SPARK	SPARK		
GND	GND		
24V(GND)	TR(GND)		
MV/PV	PV/MV		
24V	TH(24V)		
PV	PV		
MV	MV		

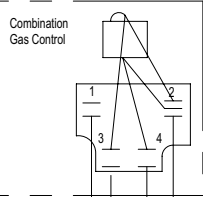

Caution
Failure to wire this unit according to this wiring diagram may result in injury to the installer or user. For deviations contact the factory.

Note to installer:
Attach this diagram near heater.

All wiring must comply with national electric code and all local codes.

All components must agree with their respective power source.

Use 105° wire for replacements.

Some models may have limit control to pressure switch wire routed outside of J-box.

* Alternate Xfmr.
Primary Xfmr Wires
230V/60Hz/1Ø-BK & Y (OR O)
200V/60Hz/1Ø-BK & R
Wire nut the wire not used.

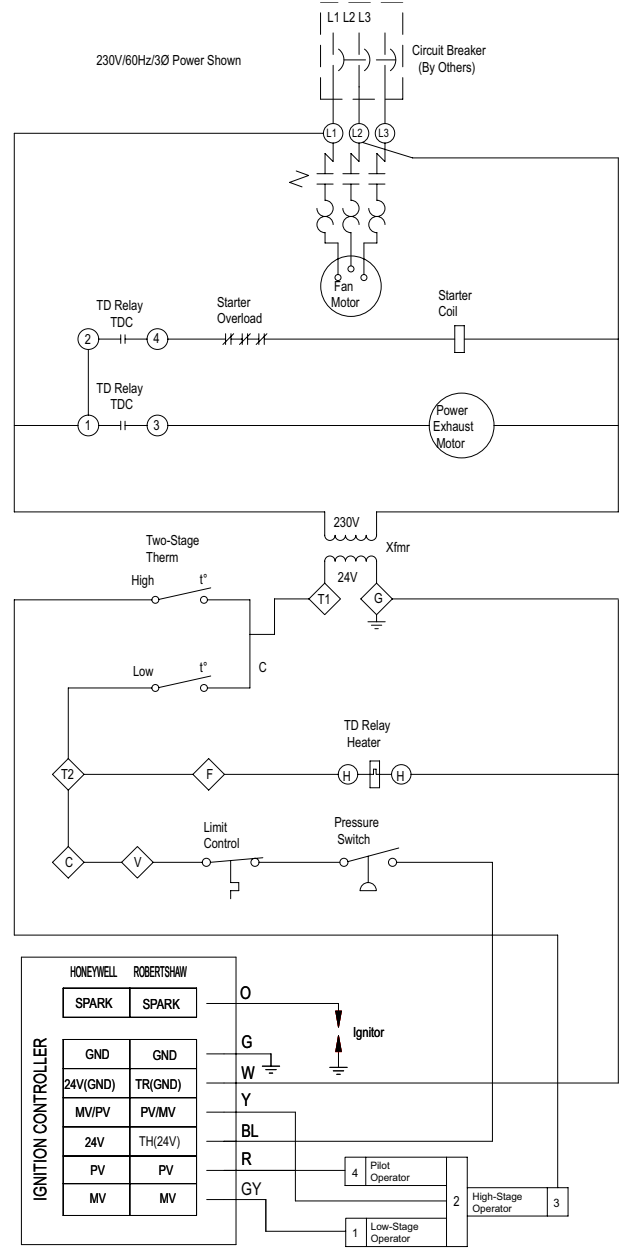

◇ Indicates Terminal Board Connection

UNIT HEATER WIRING DIAGRAM

Wiring Legend	
Factory	Line 24V.
Field	---
Wire Nut	—○—

5H78233B8

Single-Stage, Standing Pilot, 100% Shut-Off, Three-Phase.

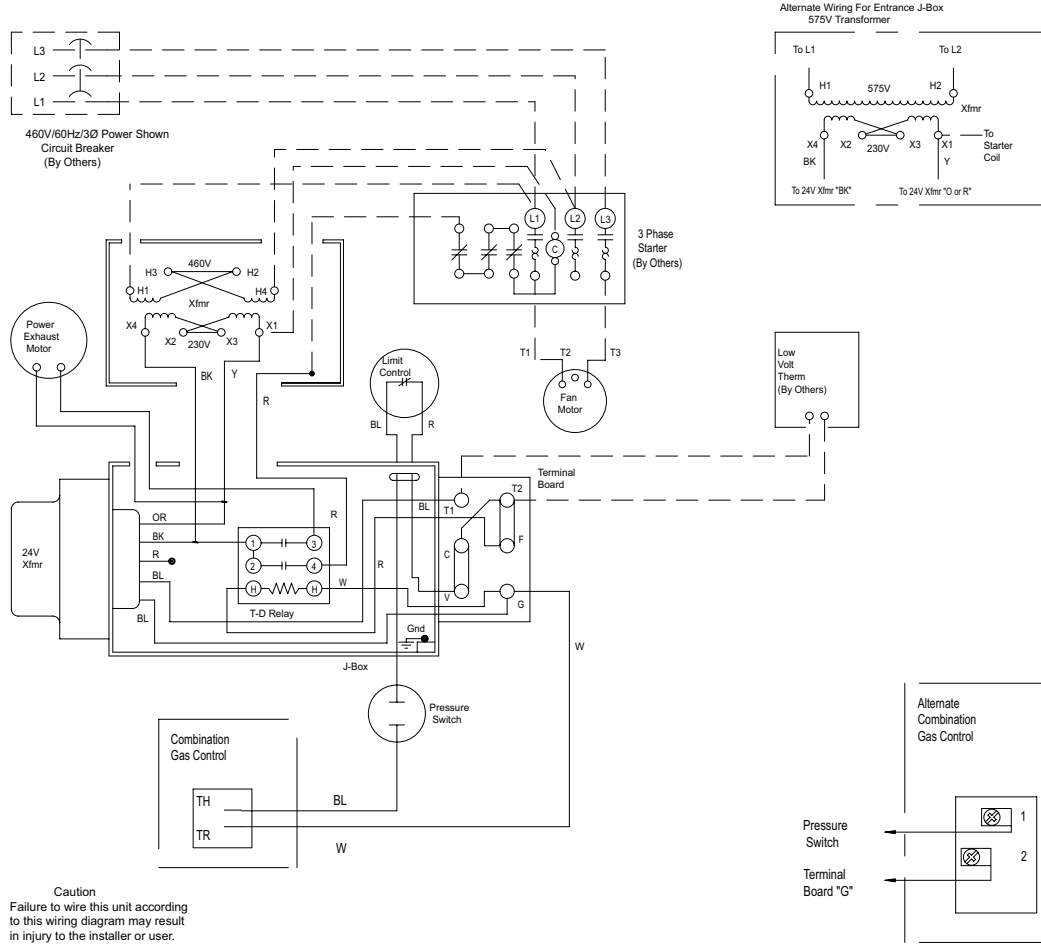

Caution
Failure to wire this unit according to this wiring diagram may result in injury to the installer or user. For deviations contact the factory.

Note to installer:
Attach this diagram near heater.

All wiring must comply with national electric code and all local codes.

All components must agree with their respective power source.

Use 105° wire for replacements.

Some models may have limit control to pressure switch wire routed outside of J-box.

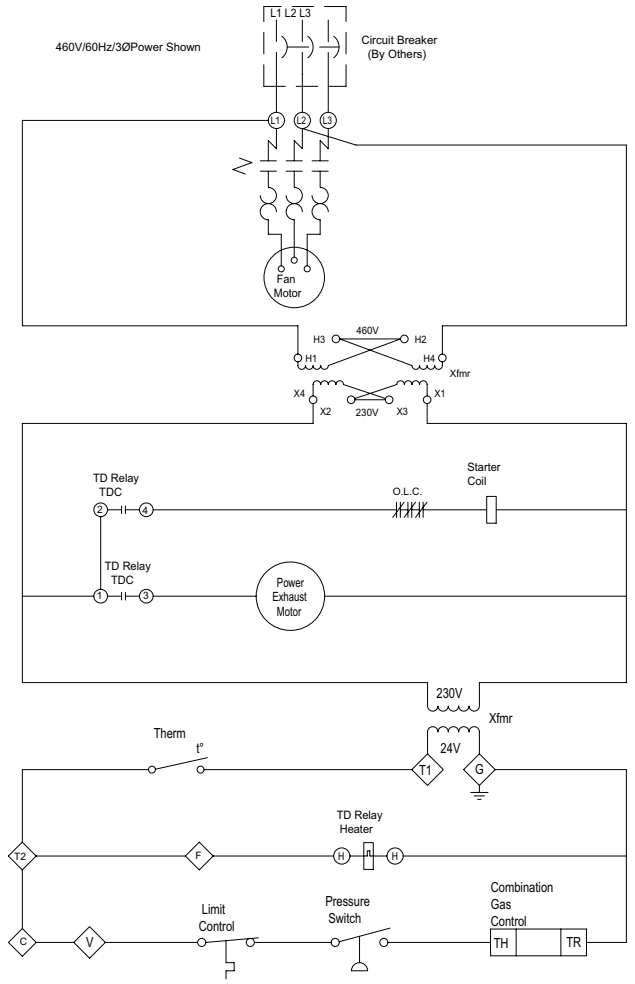

◇ Indicates Terminal Board Connection

UNIT HEATER WIRING DIAGRAM

Wiring Legend	
Factory	Line 24V.
Field	---
Wire Nut	○

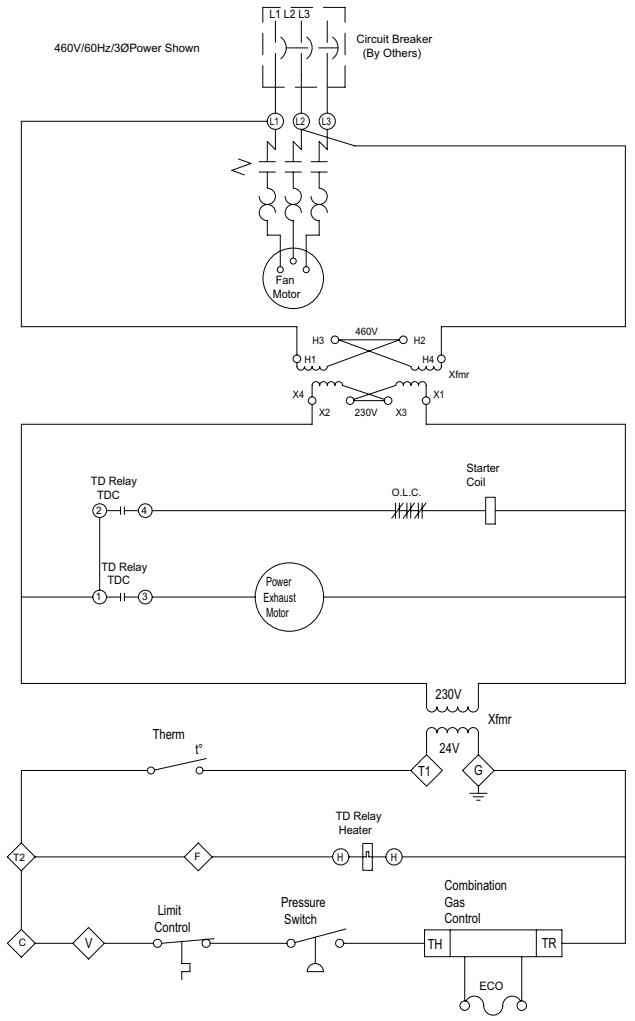
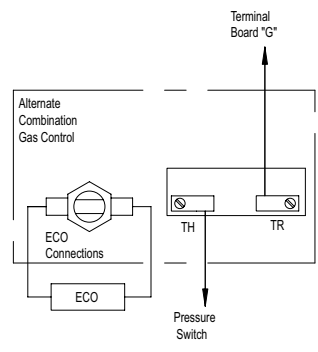
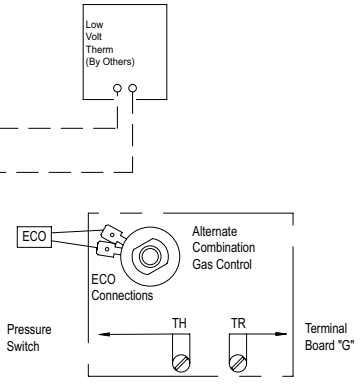
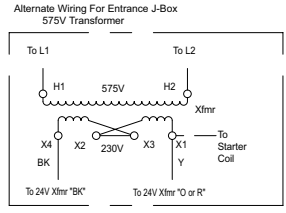
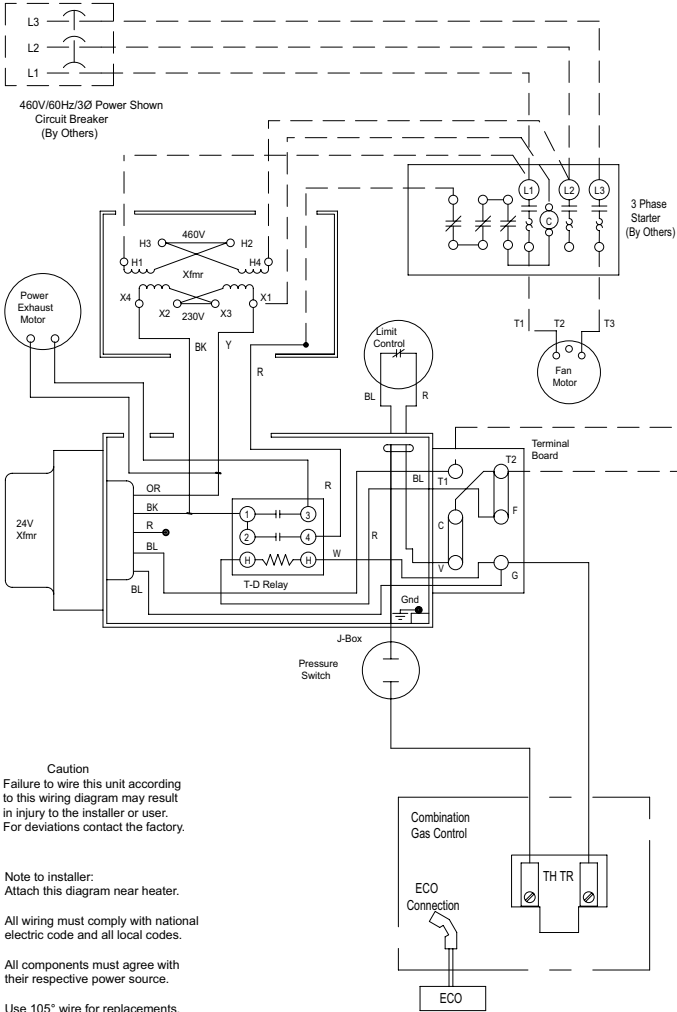

◇ Indicates Terminal Board Connection

Caution
Failure to wire this unit according to this wiring diagram may result in injury to the installer or user. For deviations contact the factory.

Note to installer:
Attach this diagram near heater.

All wiring must comply with national electric code and all local codes.

All components must agree with their respective power source.

Use 105° wire for replacements.

Some models may have limit control to pressure switch wire routed outside of J-box.

UNIT HEATER WIRING DIAGRAM

Wiring Legend	
Factory	Line 24V.
Field	---
Wire Nut	○

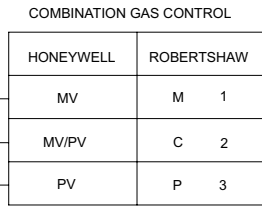
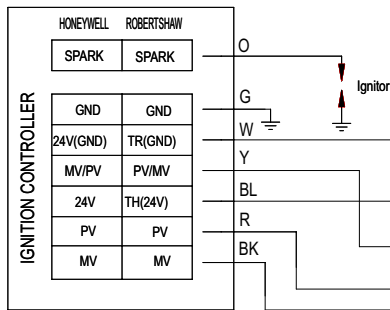
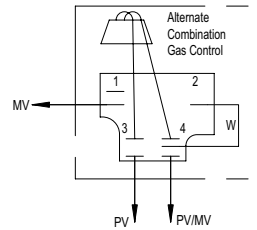
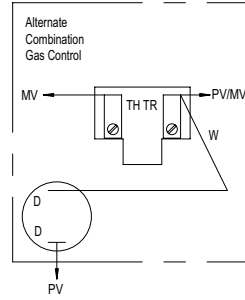
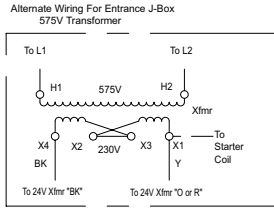
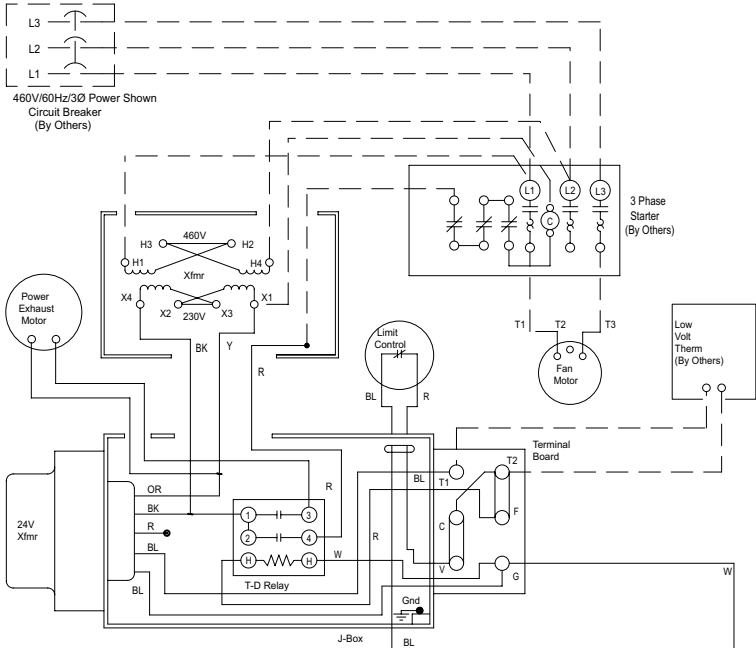

Caution
Failure to wire this unit according to this wiring diagram may result in injury to the installer or user. For deviations contact the factory.

Note to installer:
Attach this diagram near heater.

All wiring must comply with national electric code and all local codes.

All components must agree with their respective power source.

Use 105° wire for replacements. Some models may have limit control to pressure switch wire routed outside of J-box.

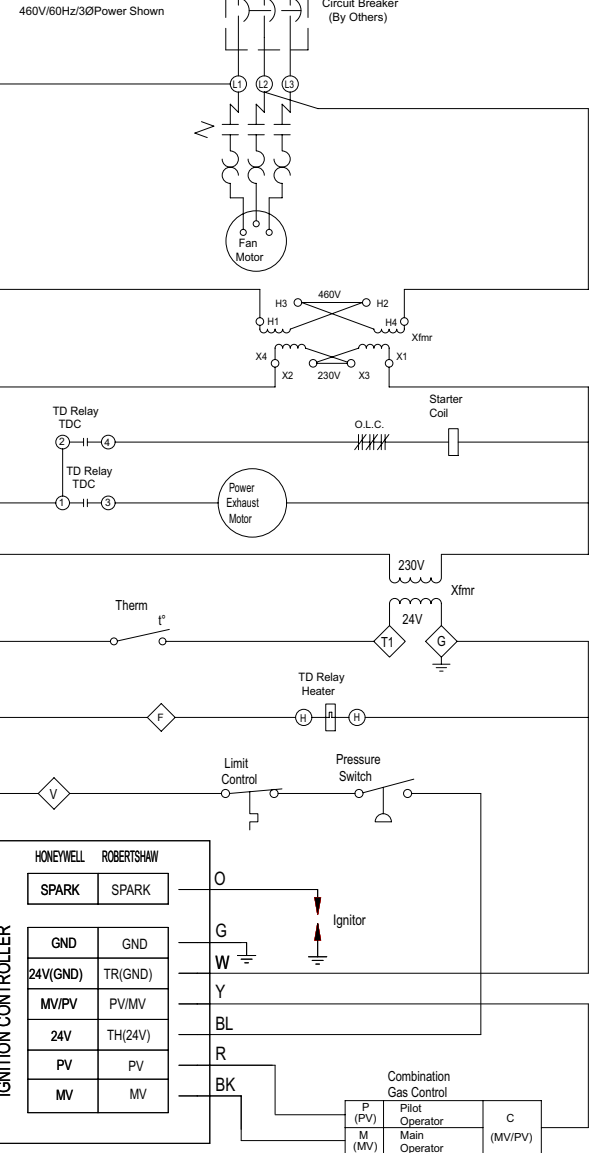

◇ Indicates Terminal Board Connection

UNIT HEATER WIRING DIAGRAM

Wiring Legend	
Factory	Line 24V.
Field	
Wire Nut	

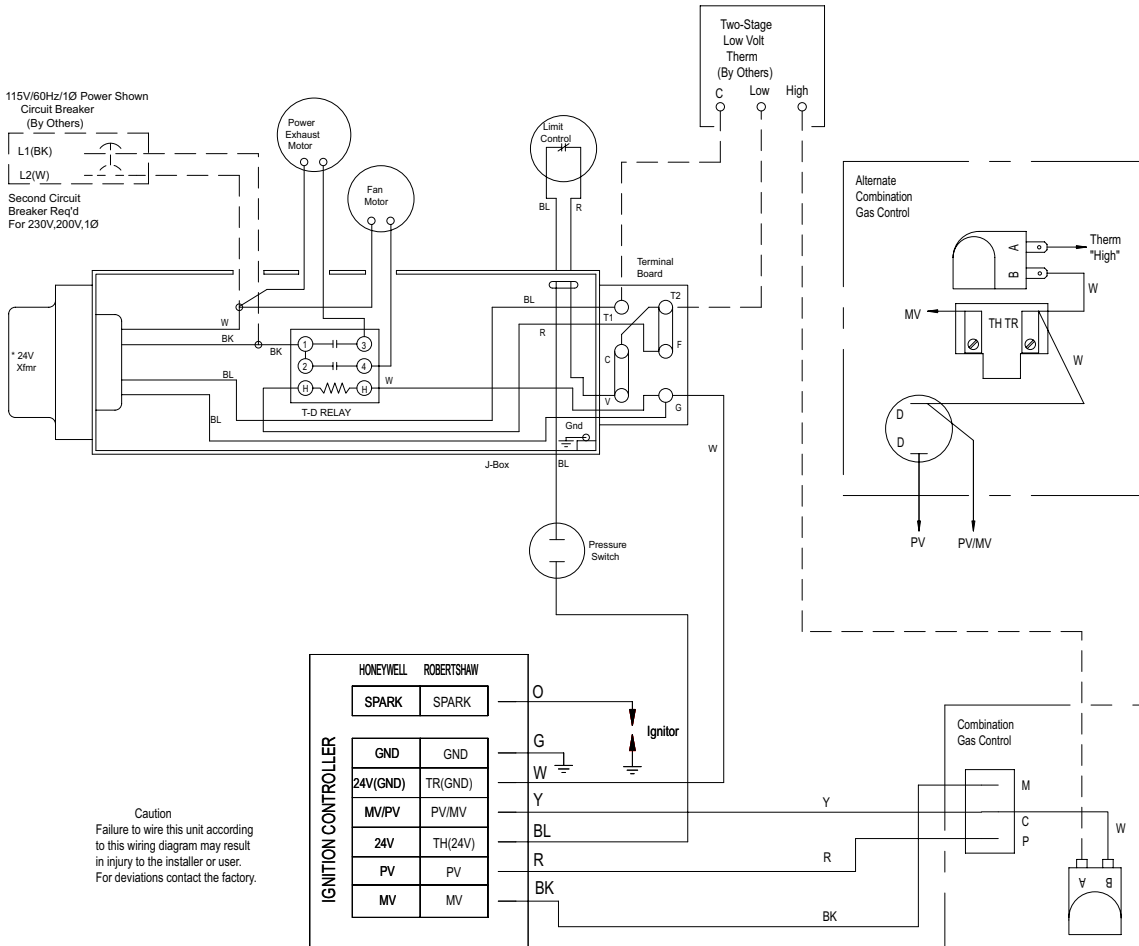

Caution
Failure to wire this unit according to this wiring diagram may result in injury to the installer or user. For deviations contact the factory.

Note to installer:
Attach this diagram near heater.

All wiring must comply with national electric code and all local codes.

All components must agree with their respective power source.

Use 105°C wire for replacements.

Some models may have limit control to pressure switch wire routed outside of J-box.

* Alternate Xfmr.
Primary Xfmr Wires
230V/60Hz/1Ø-BK & Y (OR O)
200V/60Hz/1Ø-BK & R
Wire nut the wire not used.

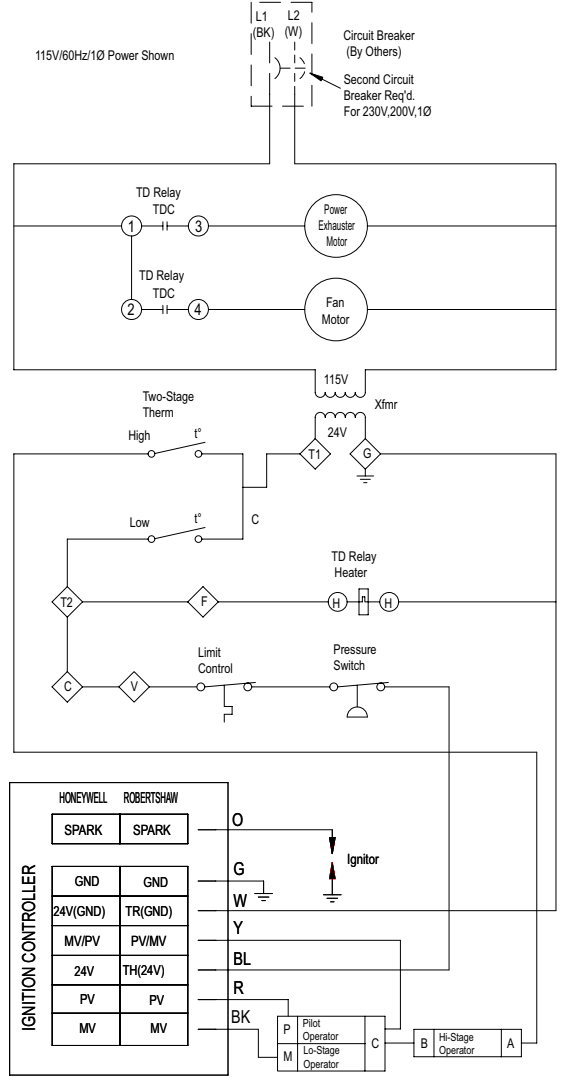

◇ Indicates Terminal Board Connection

UNIT HEATER WIRING DIAGRAM

Wiring Legend		
Factory	Line	24V
Field	---	---
Wire Nut	---	---

230V/60Hz/3Ø Power Shown
Circuit Breaker
(By Others)

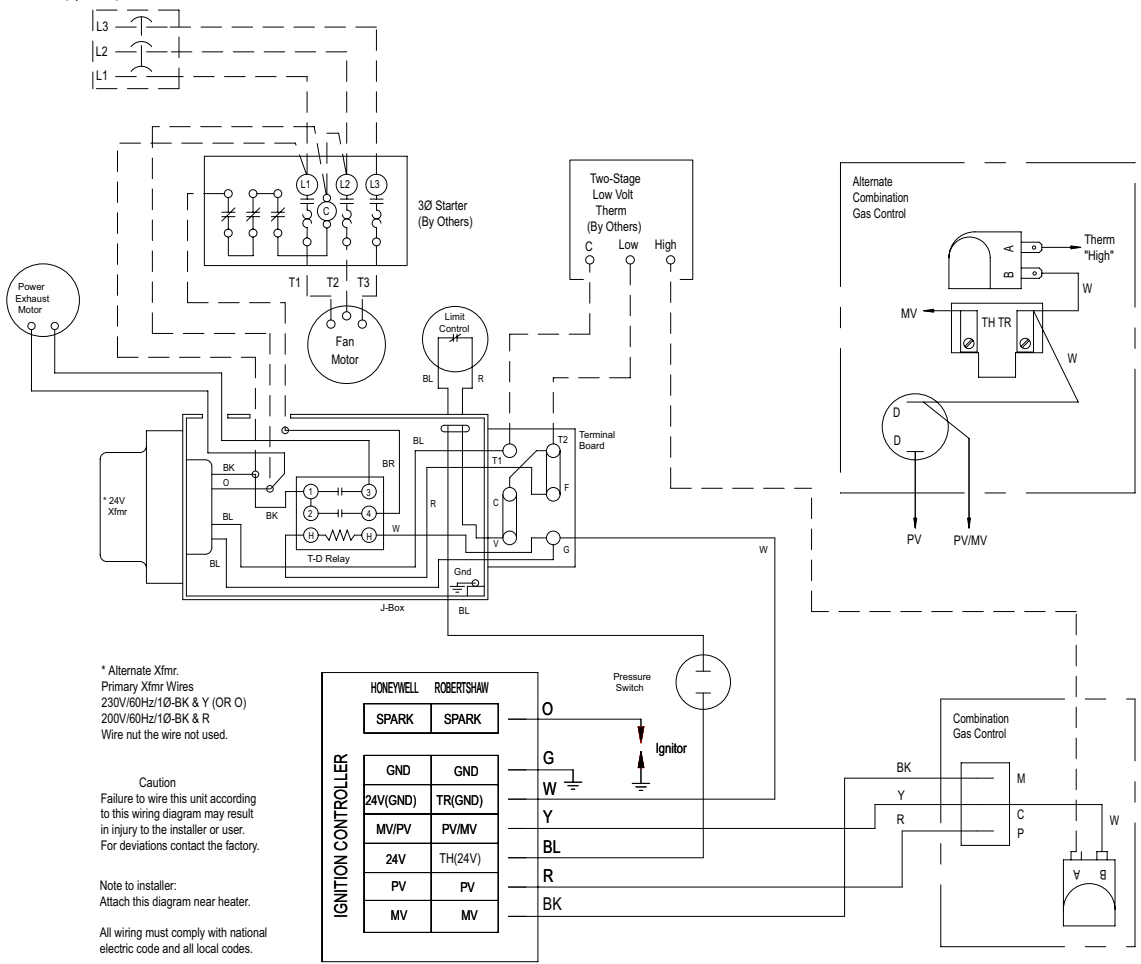

* Alternate Xfmr.
Primary Xfmr Wires
230V/60Hz/1Ø-BK & Y (OR O)
200V/60Hz/1Ø-BK & R
Wire nut the wire not used.

Caution
Failure to wire this unit according to this wiring diagram may result in injury to the installer or user. For deviations contact the factory.

Note to installer:
Attach this diagram near heater.

All wiring must comply with national electric code and all local codes.

All components must agree with their respective power source.

Use 105°C wire for replacements.

Some models may have limit control to pressure switch wire routed outside of J-box.

5H78233C3 REV A

Two-Stage, Intermittent Pilot Ignition, 100% Shut-Off, with Continuous Retry, Three-Phase.

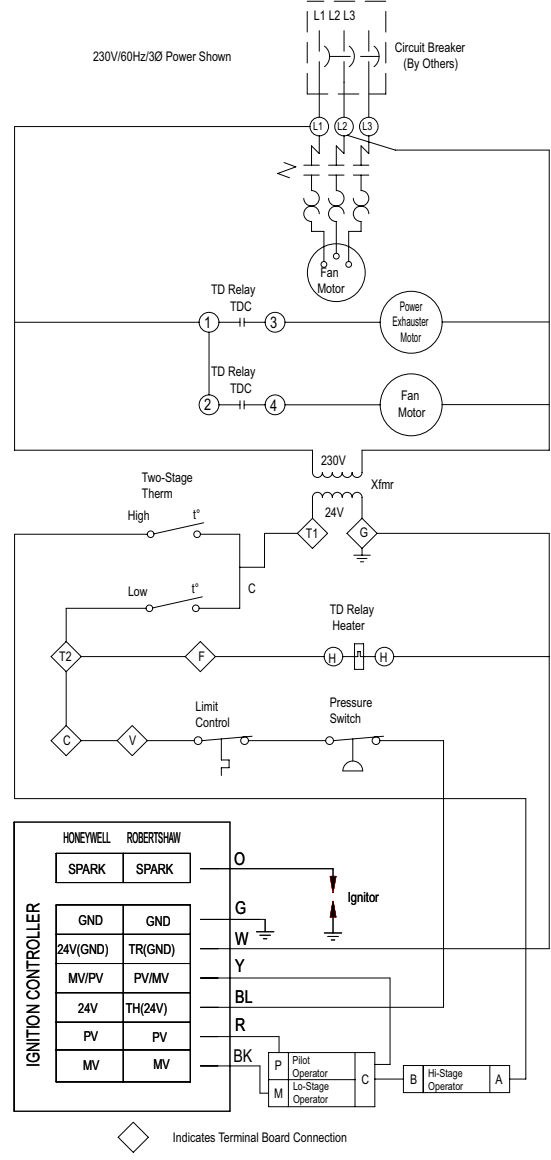

◇ Indicates Terminal Board Connection

6-446 — WIRING INSTRUCTIONS FOR ENERGY SAVER CONTROL

CAUTION

Turn off all power and gas to unit before wiring. Failure to wire this unit according to this wiring diagram may result in injury to the installer or user. For deviations, contact factory.

Installation

All wiring for this control must comply with the National Electric Code and all local codes and ordinances.

Do not locate control on an outside wall or where it will be affected by drafts or radiant heat. It does not require level mounting.

1. Remove front cover and one wiring access knockout from control.
2. Attach control to mounting surface with three screws through back of case. Use a wooden shim for insulation if surface is metal or masonry.
3. Thread two wires through knockout and connect to R and W control terminals. Leads must be long enough to extend to unit heater junction box.
4. Disconnect power to unit heater and open junction box on unit heater. Select correct wiring diagram for unit heater model (and size if applicable) and complete wiring of control to unit.

Before proceeding with wiring the accessories described, make sure the unit has been installed, vented piped and wired according to the Installation/Service Manual and Standard Wiring Diagram furnished with the unit heater.

Operational Check

1. Set room thermostat to its lowest setting and restore power supply to unit heater.
2. Familiarize yourself with the adjustment knob of the energy-saver control. In step 5 you will want to set it at 3-6 degrees (approximately) above the thermostat, but for now, turning the dial clockwise to a lower setting simulates a rise in temperature and only the unit heater fan should come on. If the wiring is correct, the controlled equipment will switch on and off as the temperature dial indicates the approximate space temperature.
3. If the controlled equipment does not start and stop as the thermostat dial is turned, disconnect the power supply and check the wiring and terminal connections.
4. If the controlled equipment operates opposite to the sequence desired, shut off the power and check for reversed leads on the switch.
5. After checkout, reset room thermostat to desired comfort level. Set energy-saver control 3 to 6 degrees above room thermostat (depending on mounting height, room conditions, etc.) for ceiling air circulation.

Gravity Vented, Propeller and Blower Models – (Single and Three Phase)

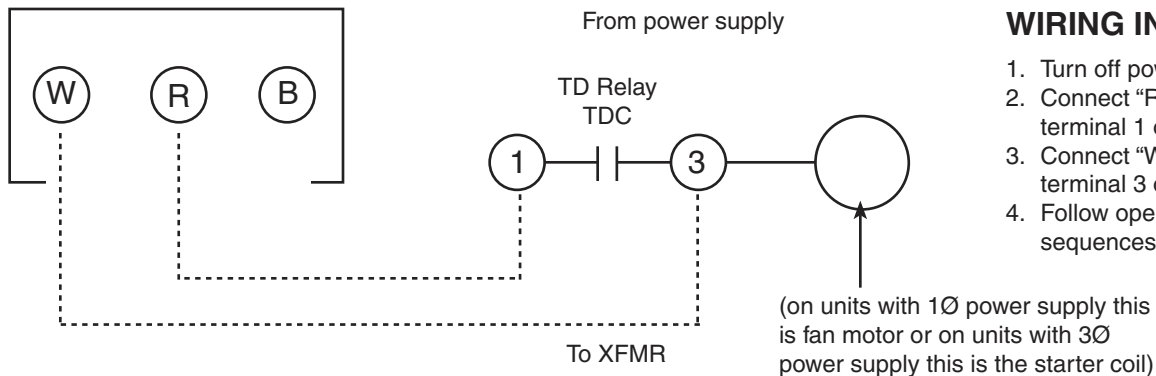

WIRING INSTRUCTIONS:

1. Turn off power to unit heater.
2. Connect "R" of Energy Saver to terminal 1 of time delay relay.
3. Connect "W" of Energy Saver to terminal 3 of time delay relay.
4. Follow operational check sequences on prior page.

Power Exhausted, Propeller and Blower Models – (Single and Three Phase)

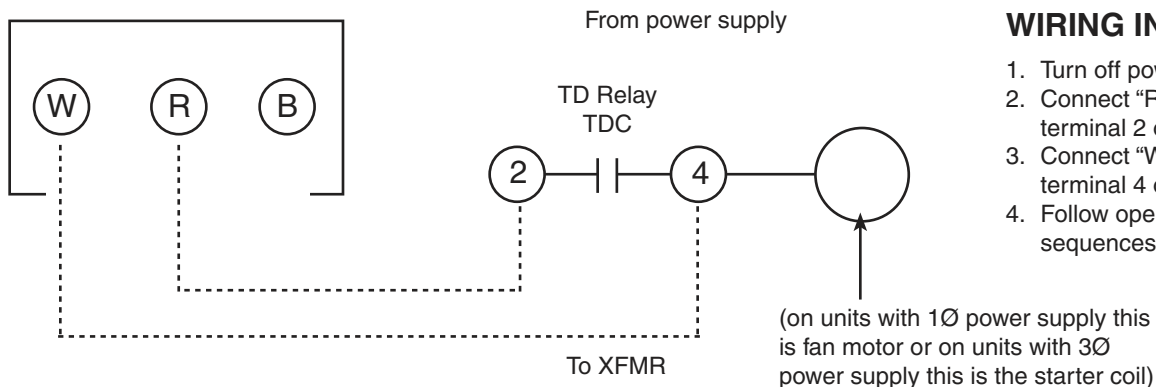

WIRING INSTRUCTIONS:

1. Turn off power to unit heater.
2. Connect "R" of Energy Saver to terminal 2 of time delay relay.
3. Connect "W" of Energy Saver to terminal 4 of time delay relay.
4. Follow operational check sequences on prior page.

6-446 — MODELS PDP/BDP TYPICAL SUMMER/WINTER SWITCH WIRING

CAUTION

Turn off all power and gas to unit before wiring. Failure to wire this unit according to this wiring diagram may result in injury to the installer or user. For deviations, contact factory.

Before proceeding with wiring the accessories described, make sure the unit has been installed, vented piped and wired according to the Installation/Service Manual and Standard Wiring Diagram furnished with the unit heater.

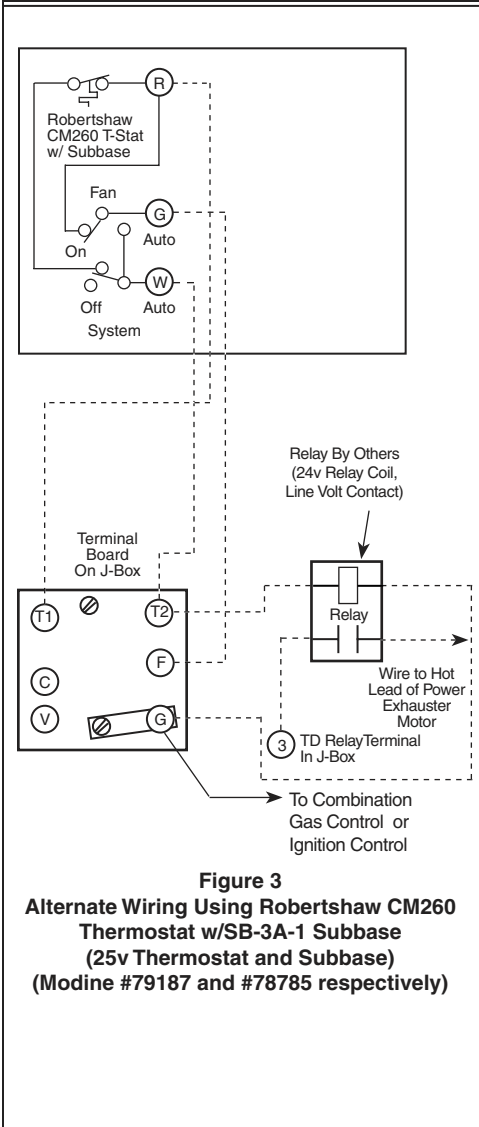
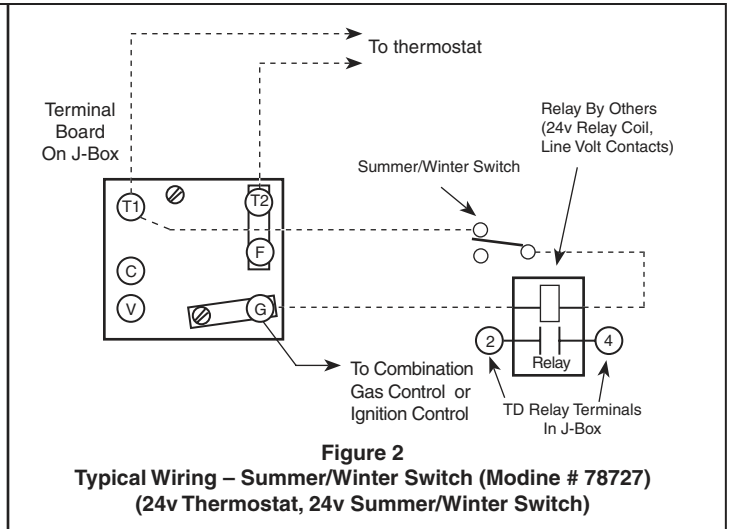
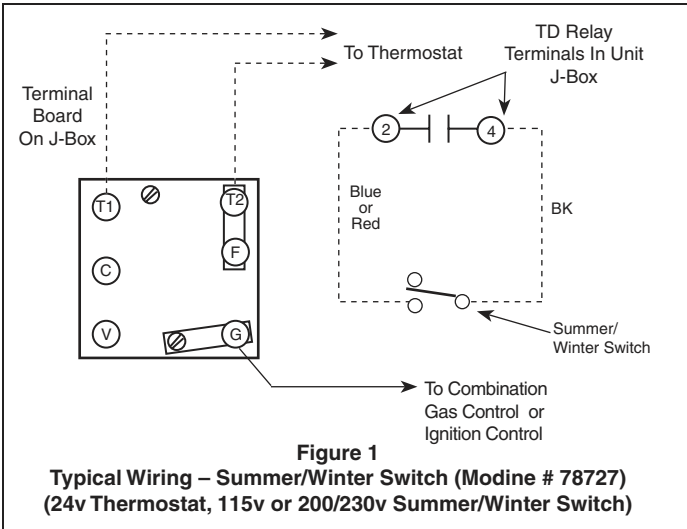

1. Turn off gas and power supply to unit.
2. Determine which method of summer/winter control is desired, Figure 1, 2 or 3.
3. Wire unit according to the method selected. **Note: If the method selected is as described in Figure 3, the factory supplied buss bar between terminals "T2" and "F" must be removed prior to wiring in thermostat and subbase.**
4. Check wiring using the Check-Out Procedure.

Check-Out Procedure

With the power and gas supply turned off, set the thermostat to its lowest setting and place the summer/winter switch to the winter position. After making these adjustments proceed as follows:

1. Turn on gas and power supply to the unit. Nothing should happen.
2. Place the summer/winter switch in the summer position. The fan motor should start, except when wired as shown in Figure 3. In that case, after a delay of 30 to 90 seconds, the fan motor should start.
3. While the summer/winter switch is still in the summer position, and with the fan motor running, turn the thermostat up to call for heat. The power exhauster motor should come on, the pressure switch should close, and the main burner should fire. Allow burner to fire for 1 to 2 minutes.
4. Turn the thermostat down again. The main burner should shut off and the fan motor should continue to run. During this step, allow the fan to run at least 90 seconds to make sure it will continue running. Modine units are equipped with a time delay relay and the motor will run 30 to 90 seconds after the time delay relay has been de-energized.
5. After insuring that the fan motor will continue to run in the summer position, and with the thermostat set to its lowest setting, place the summer/winter switch in the winter position and wait for the time delay relay to turn the fan motor off.
6. After the fan motor has stopped, and with the summer/winter switch in the winter position, turn the thermostat up to call for heat. The power exhauster motor should come on, the pressure switch should close, the main burner should fire and after a delay of 30 to 90 seconds, the fan motor should run.

If the above sequence of operation does not occur, recheck all wiring until the necessary correction to the wiring is found and corrected. Set the thermostat to the desired set point and place summer/winter switch in desired position. Unit is now ready for use.

For SERVICE contact your local qualified installation and service contractor or appropriate utility company

As Modine Manufacturing Company has a continuous product improvement program, it reserves the right to change design and specifications without notice.

Commercial HVAC&R Division • Modine Manufacturing Company • 1500 DeKoven Avenue • Racine, Wisconsin 53403-2552
Tel: 1.800.828.4328 (HEAT) • www.modine.com

© Modine Manufacturing Company 2005

4/05 - Litho in USA

[Heater Parts from ACF Greenhouses](#)